

# Scientific Calculator

# *fx-991CW+ UK*

## *User's Guide*

CASIO Worldwide Education Website

<https://edu.casio.com>

Manuals are available in multi languages at

<https://world.casio.com/manual/calc/>

# Table of Contents

---

<b>Before Using the Calculator .....</b>	<b>6</b>
Read This First .....	6
About This Manual .....	6
Key Operations .....	6
Menu Operations .....	7
Ⓚ Key and ⓧ Key .....	8
Examples .....	8
Initializing the Calculator .....	8
Calculator "Get Started" Screen .....	8
Precautions .....	9
Safety Precautions .....	9
Handling Precautions .....	12
Getting Started .....	12
Attaching and Removing the Front Cover .....	12
Turning Power On and Off .....	14
HOME Screen .....	15
Adjusting Display Contrast .....	15
Key Markings .....	15
Indicators .....	16
Using Menus .....	17
<b>Calculator Apps and Menus .....</b>	<b>21</b>
Calculator Apps .....	21
Selecting a Calculator App .....	21
Installed Calculator App List .....	21
Using the SETTINGS Menu .....	23
Changing Calculator Settings .....	24
Items and Available Setting Options .....	24
Using the CATALOG Menu and CATALOG List .....	30
CATALOG Menu .....	30
CATALOG List .....	30
Example Operations .....	30
Using the TOOLS Menu .....	31
<b>Inputting Expressions and Values .....</b>	<b>33</b>
Basic Input Rules .....	33
Inputting an Expression Using Natural Textbook Format (MathI/MathO or MathI/DecimalO Only) .....	34
Undo Operations .....	35
Using Values and Expressions as Arguments .....	35
Overwrite Input Mode (LineI/LineO or LineI/DecimalO Only) .....	35
<b>Basic Calculations .....</b>	<b>36</b>
Arithmetic Calculations .....	36

Fraction Calculations .....	36
Powers, Power Roots, and Reciprocals .....	38
Pi, Natural Logarithm Base $e$ .....	41
Pi .....	41
Natural Logarithm Base $e$ .....	41
Calculation History and Replay .....	42
Calculation History .....	42
Replay .....	42
Using Memory Functions .....	43
Answer Memory (Ans) .....	43
Variables (A, B, C, D, E, F, $x, y, z$ ) .....	43
Clearing the Contents of All Memories .....	45
<b>Changing Calculation Result Format .....</b>	<b>47</b>
Toggling Calculation Results between Standard (Fraction, $\pi$ , $\sqrt{\quad}$ Form) and Decimal .....	47
Changing the Display Format of Calculation Results (FORMAT Menu) ... .....	48
FORMAT Menu List .....	48
Conversion Sample Operation .....	49
Standard and Decimal Conversion .....	49
Prime Factorization .....	50
Recurring Decimal Conversion (Recurring Decimal Calculations) .....	51
Converting a Calculation Result to a Recurring Decimal Value .....	51
Inputting a Recurring Decimal .....	51
Recurring Decimal Calculation Example .....	52
Rectangular and Polar Coordinate Conversion .....	53
Improper Fraction and Mixed Number Conversion .....	53
Standard Form ( $a \times 10^n$ ) .....	54
Sexagesimal Conversion (Degree, Minute, Second Calculations) .....	54
Converting a Decimal Value Calculation Result to a Sexagesimal Value ...	54
Inputting and Calculating with a Sexagesimal Value .....	54
<b>Advanced Calculations .....</b>	<b>56</b>
Function Analysis .....	56
Derivative( $d/dx$ ) .....	56
Integration( $\int$ ) .....	57
Summation( $\Sigma$ ) .....	59
Logarithm( $\log_{ab}$ ), Logarithm( $\log$ ) .....	60
Natural Logarithm .....	60
Probability .....	60
% .....	61
Factorial(!) .....	61
Permutation(P), Combination(C) .....	61
Random Number .....	62
Random Integer .....	62
Numeric Calculations .....	63

GCD, LCM .....	63
Absolute Value .....	63
Recurring Decimal .....	63
Round Off .....	64
Angle Unit, Polar/Rectangular Coordinate, Sexagesimal .....	64
Degrees, Radians, Gradians .....	64
Rect to Polar, Polar to Rect .....	65
Degrees, Minutes, Seconds .....	65
Hyperbolic, Trigonometric .....	66
Hyperbolic Functions .....	66
Trigonometric Functions .....	66
Scientific Constants .....	67
Unit Conversions .....	68
Others .....	69
<b>Registering and Using Defining Equations for <math>f(x)</math> and <math>g(x)</math></b> .....	<b>71</b>
Registering and Using Defining Equations for $f(x)$ and $g(x)$ .....	71
Registering a Defining Equation .....	71
Performing a Calculation by Assigning a Value to the Registered Defining Equation .....	72
Registering a Composite Function .....	72
Data Retention .....	73
<b>Using QR Code Functions</b> .....	<b>74</b>
Using QR Code Functions .....	74
Displaying a QR Code .....	74
If You Experience Difficulty Scanning a QR Code .....	75
<b>Using Calculator Apps</b> .....	<b>76</b>
Statistical Calculations .....	76
General Procedure for Performing a Statistical Calculation .....	76
Inputting Data with Statistics Editor .....	77
Displaying Statistical Calculation Results .....	80
Using Statistical Calculation Screen .....	84
Statistical Calculation Formula .....	90
Creating a Number Table .....	93
General Procedure for Creating a Number Table .....	93
Maximum Number of Rows in a Number Table According to Table Type ....	94
Defining Equation Registration .....	95
Editing Number Table Screen Data .....	95
$f(x)$ and $g(x)$ Update Timing .....	96
Data Retention .....	96
Equation Calculations .....	97
Simultaneous Linear Equations .....	97
High-order Equations from 2nd to 4th Degree .....	99
Using Solver .....	103

Inequality Calculations .....	105
General Procedure for Performing an Inequality Calculation .....	105
Distribution Calculations .....	106
General Procedure for Performing a Distribution Calculation .....	107
Parameter List .....	108
List Screen .....	109
Editing the List Screen Contents .....	110
Calculation Example .....	111
Complex Number Calculations .....	111
Inputting Complex Numbers .....	111
Complex App Calculation Examples .....	112
Matrix Calculations .....	114
General Procedure for Performing a Matrix Calculation .....	114
Matrix Variable List Screen .....	116
Matrix Answer Memory (MatAns) .....	118
Matrix Calculation Examples .....	119
Vector Calculations .....	121
General Procedure for Performing a Vector Calculation .....	121
Vector Variable List Screen .....	123
Vector Answer Memory (VctAns) .....	125
Vector Calculation Examples .....	126
Using Spreadsheet .....	127
Inputting and Editing Cell Contents .....	128
Inputting a Constant and Formula into a Cell .....	128
Cell Relative and Absolute References .....	130
Using Spreadsheet App Special Commands .....	131
Batch Inputting the Same Formula or Constant into Multiple Cells .....	132
Spreadsheet App Setting Items .....	134
Auto Calc and Recalculate .....	134
Ratio Calculations .....	134
General Procedure for Performing a Ratio Calculation .....	135
Calculation Example .....	135
Using Math Box .....	136
Dice Roll .....	136
Coin Toss .....	140
Number Line .....	143
Circle .....	147
Base- $n$ Calculations .....	150
Specifying the Number Mode of a Particular Input Value .....	152
Converting a Calculation Result to Another Type of Value .....	152
Logical and Negation Operations .....	153
<b>Technical Information .....</b>	<b>154</b>
Errors .....	154
Displaying the Location of an Error .....	154
Error Messages .....	154
Before Assuming Malfunction of the Calculator...	158

Replacing the Battery .....	159
Calculation Priority Sequence .....	159
Calculation Ranges, Number of Digits, and Precision .....	161
Calculation Range and Precision .....	161
Function Calculation Input Ranges and Precision .....	162
Specifications .....	164
<b>Frequently Asked Questions .....</b>	<b>165</b>
Frequently Asked Questions .....	165

# Before Using the Calculator

## Read This First

### About This Manual

- In no event shall CASIO Computer Co., Ltd. be liable to anyone for special, collateral, incidental, or consequential damages in connection with or arising out of the purchase or use of this product and items that come with it. Moreover, CASIO Computer Co., Ltd. shall not be liable for any claim of any kind whatsoever by any other party arising out of the use of this product and the items that come with it.
- The contents of this manual are subject to change without notice.
- The displays and illustrations (such as key markings) shown in this manual are for illustrative purposes only, and may differ somewhat from the actual items they represent.
- QR Code is a registered trademark of DENSO WAVE INCORPORATED in Japan and in other countries.
- Company and product names used in this manual may be registered trademarks or trademarks of their respective owners.

### Key Operations

The example below shows how key operations are represented in this manual.

**Example 1:**  $\text{AC}$   $\sqrt{\square}$   $9$   $\text{EXE}$

Keys should be pressed in the sequence shown above (left to right).

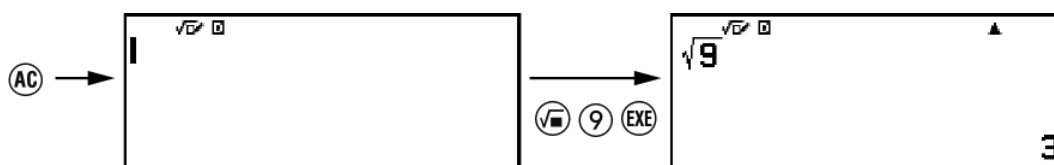

**Example 2:**  $\uparrow$   $7$   $(\pi)^*$

The above indicates you should press  $\uparrow$  and then  $7$ , which will input a  $\pi$  symbol. All multiple-key input operations are indicated like this. Key cap markings are shown, followed by the input character or command in parentheses.

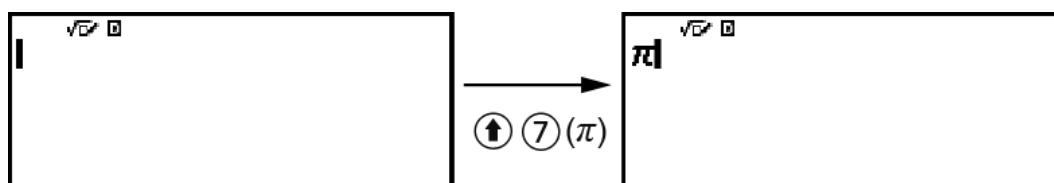

\* Refer to **"Key Markings" (page 15)** for more information about the key symbols used in this example.

**Example 3:** ⤴, ⤵, ⤶, ⤷, ⤴, ⤵

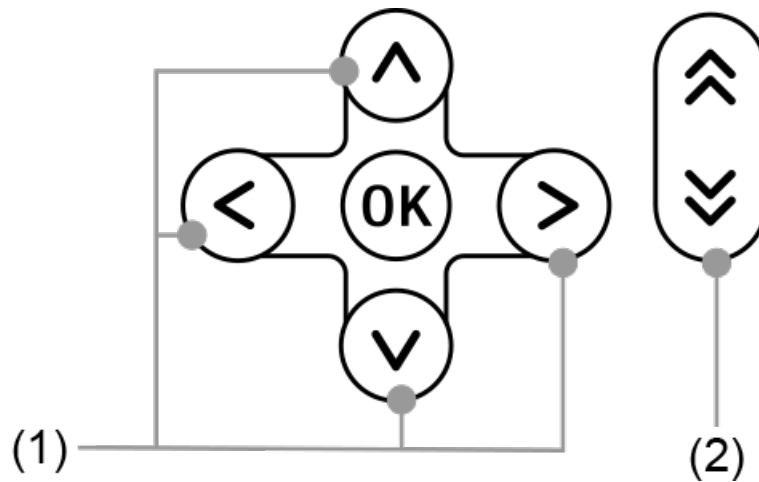

- Individual cursor keys indicated by (1) are represented as ⤴, ⤵, ⤶, ⤷.
- Individual page scroll keys indicated by (2) are represented as ⤴, ⤵.

## Menu Operations

Some operations in this manual use a simplified form of menu operations, as shown in the examples below.

### Example 1

⊞ – [Other] > [π]

or

Press ⊞, and then select [Other] > [π].



### Actual Operation 1

1. Press ⊞.
2. Use ⤴ and ⤵ to select [Other], and then press OK.
3. Use ⤴ and ⤵ to select [π], and then press OK.







### Example 2

⊞ – Calculate









or

Press , select the Calculate app icon, and then press .

## Actual Operation 2

1. Press .
2. Use the cursor keys (, , , ) to select the Calculate app icon, and then press .

## Key and Key

The  key and  key perform the same operation. In this manual,  is used for selecting or applying a setting, while  is used for executing a calculation. Note, however, that it makes no difference whether you press  or  for operations where either  or  is shown.

## Examples

If you are not instructed to use a specific calculator app or to configure particular settings for an example operation, the app and settings below are assumed.

Calculator app: Calculate







Settings: Initial default calculator settings

For information about returning the calculator to its initial default settings, see ["Initializing the Calculator" \(page 8\)](#).

# Initializing the Calculator

### Important!

- The procedure below initializes all calculator settings, except for Contrast and Auto Power Off. Also clears all data stored in calculator memory.

1. Press  to display the HOME screen.
2. Use the cursor keys (, , , ) to select a calculator app icon, and then press .
3. Press , and then select [Reset] > [Initialize All] > [Yes].
  - This displays the HOME screen.

## Calculator "Get Started" Screen

While the HOME screen is displayed, pressing the  key will display the "Get Started" screen, which includes the information below.

- QR Code for accessing the "Get Started" webpage of the Worldwide Education Service (<https://wes.casio.com/calc/cw/>)  
The Get Started webpage gives you access to the User's Guide and other related information to help you get started with your calculator.
- Calculator ID number (24-character string)

Press  to return to the HOME screen.

#### Note

- You can also display the Get Started screen, by selecting it from the SETTINGS menu. See "[Using the SETTINGS Menu](#)" (page 23).

## Precautions

---

### **|** Safety Precautions

Thank you for purchasing this CASIO product.

Be sure to read the "Safety Precautions" before using this product to ensure that you use it correctly. Be sure to keep all user documentation handy for future reference.

### Symbol Examples



The  symbol indicates something you should not do.



The  symbol indicates something you must do.



### **Danger**

Indicates something that creates the major risk of death or serious personal injury.

### ■ **Button Type and Coin Type Battery Precautions**

**Take care to ensure that a battery will not be swallowed accidentally.**



**Particular care is required to keep batteries away from children.**

Should a battery be swallowed accidentally or if there is a possibility that a battery has been swallowed, immediately contact a physician. Swallowing a battery can result in chemical burns, mucosal tissue penetration, and other serious problems that create the risk of death.



### **Warning**

Indicates something that creates the risk of death or serious personal injury.

### ■ **Display Screen**



**Do not press the LCD or subject it to strong impact.**

Doing so can cause the LCD glass to crack, creating the risk of personal injury.



**Should the LCD become cracked, never touch any of the liquid inside.**

LCD liquid getting on the skin creates the risk of skin irritation. Should LCD liquid get into your mouth, immediately rinse your mouth out and contact your physician. Should LCD liquid get in your eyes or on your skin, rinse with clean water and then contact your physician.

### ■ **Battery Precautions**



**Should fluid leaking from a battery get on your skin or clothing, immediately rinse it off with clean water.**

Battery fluid getting into the eyes creates the risk of eyesight loss, etc. Rinse the eyes and then immediately contact a physician.



### Caution

Indicates something that creates the risk of minor personal injury or physical damage.

**Observe the precautions below. Failure to do so can cause a battery to rupture, creating the risk of fire, personal injury, and soiling of nearby objects by leaking fluid.**



- Do not try to take a battery apart and never allow a battery to become shorted.
- Do not charge a non-rechargeable battery.
- Do not expose a battery to heat or throw it into fire.



- Use only the specified type of battery.
- Load a battery with its poles (plus (+) and minus (-)) facing correctly.
- Replace the battery as soon as possible after it goes dead.



### Battery Precautions

● **Observe the precautions below. Failure to do so can cause the battery to explode or leak flammable liquid or gas.**

- Remove and immediately recycle or dispose of used batteries according to local regulations and keep away from children. Do not dispose of batteries in household trash or incinerate.
- Even used batteries may cause severe injury or death.
- Call a local poison control center for treatment information.
- Use only the type of battery that is specified for this product.
- Do not burn a battery or dispose of it in an incinerator, or by mechanical crushing or cutting.
- Do not subject a battery to excessively high or low temperatures during use, storage, or transport.
- Do not subject a battery to excessively low barometric pressure during use, storage, or transport.
- Remove and immediately recycle or dispose of batteries from equipment not used for an extended period of time according to local regulations.
- Always completely secure the battery compartment.

If the battery compartment does not close securely, stop using the product, remove the batteries, and keep them away from children.

## Handling Precautions

- Even if the calculator is operating normally, replace the battery at least once every two years (LR44).  
A dead battery can leak, causing damage to and malfunction of the calculator. Never leave a dead battery in the calculator. Do not try using the calculator while the battery is completely dead.
- You will be charged for malfunction or damage due to battery leakage, which is not covered by the warranty.
- The battery that comes with the calculator discharges slightly during shipment and storage. Because of this, it may require replacement sooner than the normal expected battery life.
- Avoid use and storage of the calculator in areas subjected to temperature extremes, and large amounts of humidity and dust.
- Do not subject the calculator to excessive impact, pressure, or bending.
- Never try to take the calculator apart.
- Use a soft, dry cloth to clean the exterior of the calculator.
- Whenever discarding the calculator or batteries, be sure to do so in accordance with the laws and regulations in your particular area.

## Getting Started

---

### Attaching and Removing the Front Cover

#### To remove the front cover

Before using the calculator, remove the front cover (①) and attach it to the back (②).

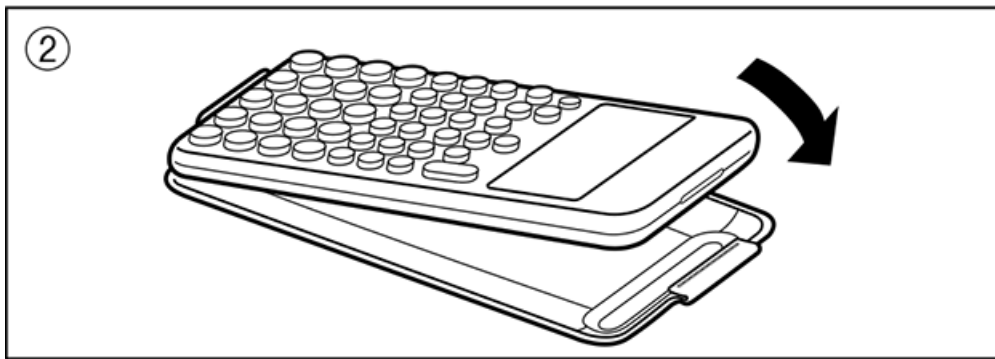
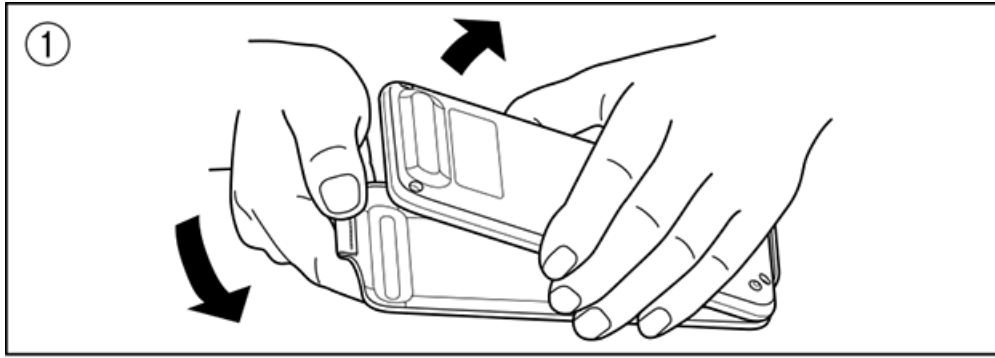

**To attach the front cover**

When you are not using the calculator, remove the front cover (①) and attach it to the front (②).

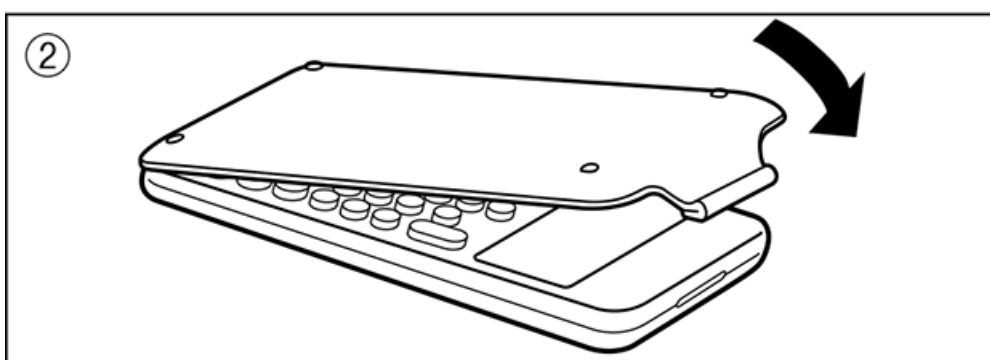
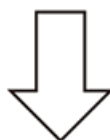
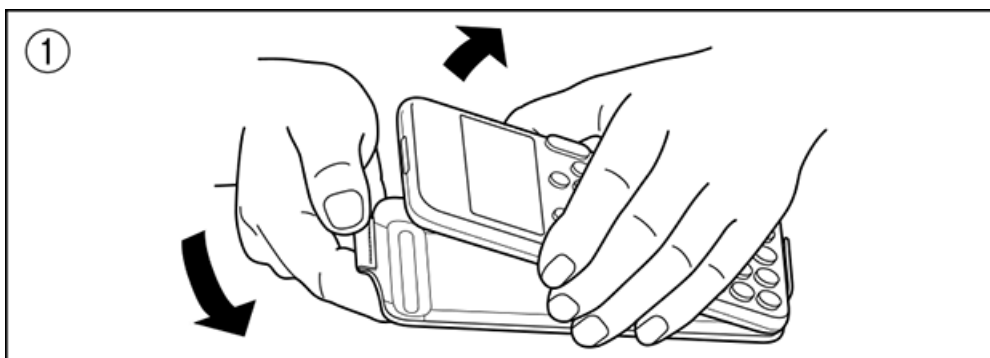



### Important!



- Always attach the front cover to the calculator whenever you are not using it. Otherwise, accidental operation of the  key can cause the power to turn on and run down the battery.

## Turning Power On and Off

Press  to turn on the calculator.

Press   (OFF) to turn off the calculator.

### Note

- To turn on power, long-press . To avoid turning on power accidentally, the top of  key is slightly lower than the other keys.
- If the screen shown below appears right after you turn on power, it means that remaining battery power is low.



If this screen appears, replace the battery as soon as possible. For details about battery replacement, see ["Replacing the Battery" \(page 159\)](#).

- The calculator also will turn off automatically after approximately 10 minutes or 60 minutes of non-use. Press the  key to turn the calculator back on.

## HOME Screen

Pressing  $\odot$  displays the HOME screen. The HOME screen shows a list of installed calculator apps.

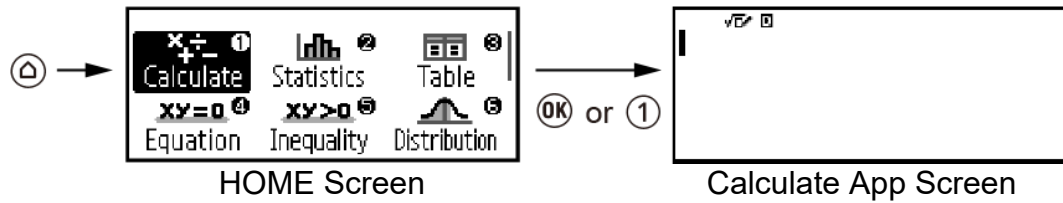

For information about installed calculator apps, see "[Installed Calculator App List](#)" (page 21).

## Adjusting Display Contrast

1. Press  $\odot$ , select a calculator app icon, and then press  $\text{OK}$ .
2. Press  $\text{Menu}$ , and then select [System Settings] > [Contrast].

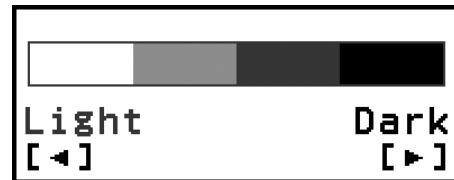

3. Use  $\leftarrow$  and  $\rightarrow$  to adjust display contrast.
4. After the setting is the way you want, press  $\text{AC}$ .

### Important!

- If adjusting display contrast does not improve display readability, it probably means that battery power is low. Replace the battery.

## Key Markings

Pressing the  $\uparrow$  key followed by a second key performs the alternate function of the second key. The alternate function is indicated by the text printed above the key, on the left.

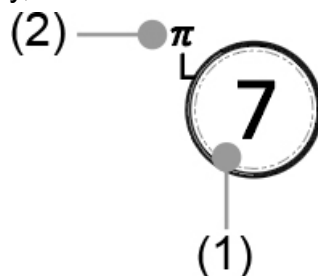

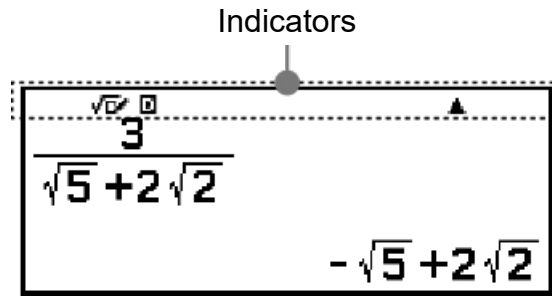

- (1) Keycap function:  $\text{7}$
- (2) Alternate function:  $\uparrow \text{7}(\pi)$

## Indicators



The table below describes indicators that appear at the top of the screen.

This indicator:	Means this:
<b>S</b>	The keypad has been shifted by pressing the  key. The keypad will unshift and this indicator will disappear when you press a key.
	MathI/MathO or MathI/DecimalO is selected for Input/Output on the SETTINGS menu.
<b>D</b> / <b>R</b> / <b>G</b>	Current setting of Angle Unit ( <b>D</b> : Degree, <b>R</b> : Radian, or <b>G</b> : Gradian) on the SETTINGS menu.
<b>FIX</b>	A fixed number of decimal places is in effect.
<b>SCI</b>	A fixed number of significant digits is in effect.
$i/\angle$	Current setting of Complex Result ( $i : a+bi$ or $\angle : r\angle\theta$ ) on the SETTINGS menu.
<b>▲</b> / <b>▼</b>	There is previous ( <b>▲</b> ) or following ( <b>▼</b> ) calculation history for the currently displayed calculation result. With some calculator apps, these indicators indicate there are other calculation results available.
	Calculator is being powered directly by its solar cells, either entirely or in some combination with the battery.

## Using Menus

Many of the operations of your calculator are performed using menu screens. The example below shows operations starting from the menu screen that appears when you press  $\text{☰}$ .

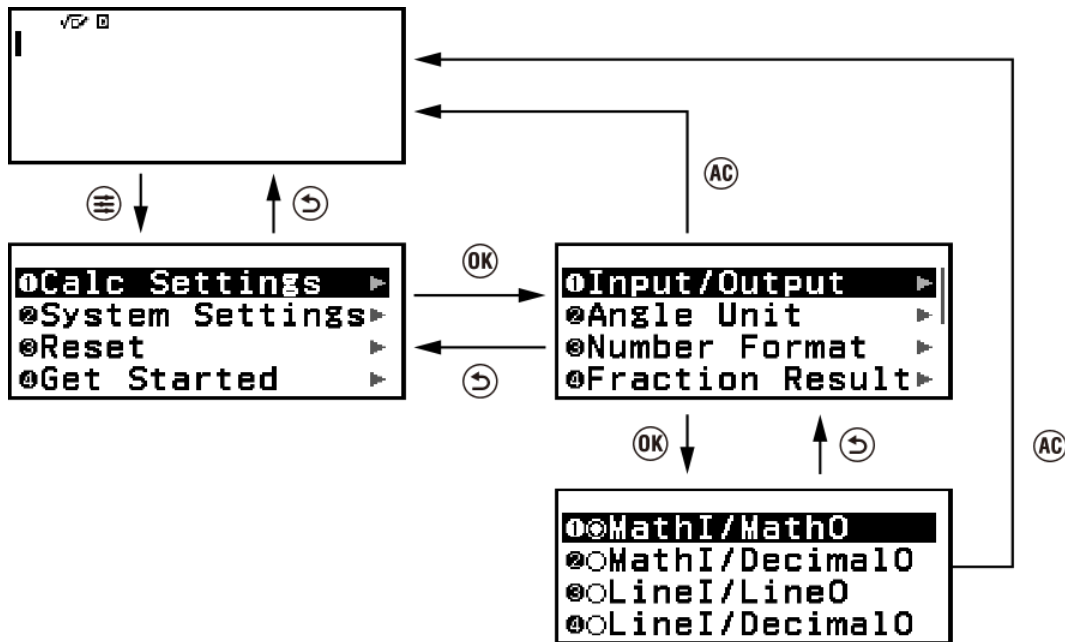

### Selecting a Menu Item

There are two ways to select an item on a menu.

- **Method 1:** Use the cursor keys to move the highlighting to the item you want to use and then press  $\text{OK}$ .
- **Method 2:** Press the key that corresponds to the number or symbol to the left of the item you want to select.

The number or symbol to the left of an item is its "Option Number".

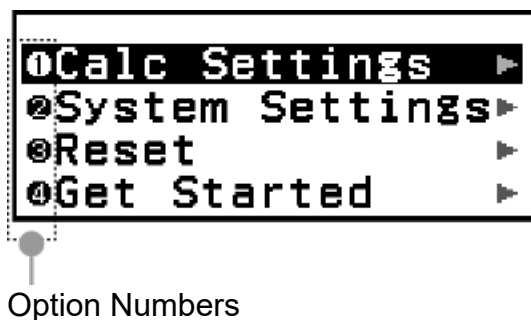

- You can use Option Numbers to select a menu by pressing its corresponding number or symbol key even if its menu is not currently displayed.
- Option Numbers are displayed when "On" is selected for the **Show Option Num (page 29)** setting on the SETTINGS menu and not displayed when "Off" is selected. The default setting is On. Note that menu operations you execute by pressing number and symbol keys

remain in effect even when "Off" is selected for the Show Option Num setting.

## Example of Menu Operations Using Option Numbers

1. Press **(F4)**, select the Calculate app icon, and then press **(F1)**.
  - This displays the Calculate app's initial screen.



2. Press **(F3)**, and then press **(F2)** to select [System Settings].
  - This displays the menu items included under [System Settings].

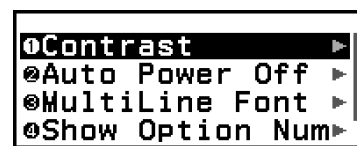

3. Press **(F4)** to select [Show Option Num].

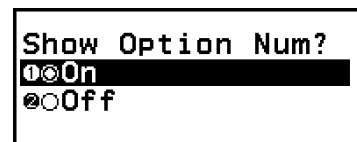

4. Press **(F2)** (Off).
  - This turns off the Show Option Num setting, which causes the Option Numbers to the left of the menu items to disappear.

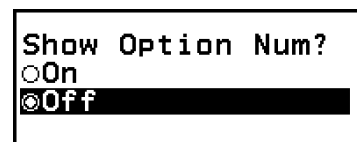

5. Press **(AC)** to close the menu.
6. Perform the following key operation: press **(F3)**, **(F2)** (System Settings), **(F4)** (Show Option Num), **(F1)** (On).
  - This turns on the Show Option Num setting, which causes the Option Numbers to reappear.

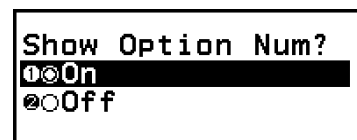

7. Press **(AC)** to close the menu.

## Navigating Between Menu Hierarchies

The "▶" indicator to the right of a menu item means that there are lower hierarchy levels under that item. Selecting the menu item and pressing **OK** or **▶** navigates the next lower level of the hierarchy. To return to the next upper level of the hierarchy, press **◀**.

### Note

- If you are in a lower level of the hierarchy of a one-column menu, you can press **◀** in addition to **▶** to return to the next higher level.

## Selecting a Menu Item with a Radio Button (○/●)

When the display shows a list of multiple options, each option will have a radio button (○ or ●) to its left. ● indicates the currently selected option.

### To configure the setting of a radio button menu item

1. Highlight the applicable menu item and then press **OK**.
  - What happens next depends on the type of menu item you selected.
    - If there are no more settings to configure for the menu item you selected, the radio button next to it will change to ●.
    - The menu item you selected has more settings to configure, a screen for selecting the menu item setting will appear. In this case, proceed to step 2.
2. On the setting screen, highlight the setting you want and then press **OK**.
  - This returns to the menu item screen in step 1, with the radio button next to the menu item you previously selected changed to ●.

## Scrolling Between Screens

A scroll bar will appear along the right side of the display when there are so many menu items that they do not fit on one screen.

- Use **▲** and **▼** to scroll between screens.
- Use **▲** and **▼** to scroll line-by-line.

## To close the menu and return to the screen displayed before the menu

Press **AC**.

### Note

- You can close a menu displayed by pressing **≡**, **⏪**, **f(x)**, **⏩**, **⏹**, or **⏶** **FORMAT** **↺** by pressing **AC**. If the displayed menu is one that appears immediately after launching

a particular calculator app or if it is an app-specific menu, you cannot close it by pressing **AC**. In that case, you must press **↵** to close the menu.

# Calculator Apps and Menus

## Calculator Apps

### Selecting a Calculator App



Select a calculator app that is suitable for the type of calculation you want to perform.

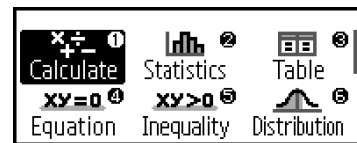





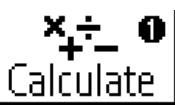

1. Press  $\odot$  to display the HOME screen.
  - For information about each calculator app, see the "[Installed Calculator App List](#)" (page 21).





2. Use the cursor keys to move the highlighting to the icon of the app you want to start up, and then press  $\odot$ .  
Alternatively, you can press a key that is shown in the upper right corner of the icon to start up an app.
  - If 1 is shown in the upper right corner of the icon, press  $\textcircled{1}$ .

### Installed Calculator App List

Icon	Description
 Calculate (Calculate)	General calculations
 Statistics (Statistics)	Statistical and regression calculations
 Table (Table)	Generates a number table based on one or two functions

 <b>Equation</b> (Equation)	Simultaneous equations, higher-order equations, and Solver (function to find the value of any variable contained in an input equation)
 <b>Inequality</b> (Inequality)	Inequality calculations
 <b>Distribution</b> (Distribution)	Distribution calculations
 <b>Complex</b> (Complex)	Complex number calculations
 <b>Matrix</b> (Matrix)	Matrix calculations
 <b>Vector</b> (Vector)	Vector calculations
 <b>Spreadsheet</b> (Spreadsheet)	Spreadsheet calculations
 <b>Ratio</b> (Ratio)	Ratio calculations

 <b>Math Box</b>  (Math Box)	The following functions to support math learning. Dice Roll, Coin Toss: Probability simulation Number Line: Number line graphs for up to three equalities or inequalities Circle: Angles and trigonometric values shown using a Unit Circle or Half Circle figure. Angles can also be shown using a Clock figure.
 <b>Base-N</b>  (Base-N)	Calculations involving specific number systems (binary, octal, decimal, hexadecimal)

## Using the SETTINGS Menu

---

To display the SETTINGS menu, press  while using a calculator app. The SETTINGS menu includes the menu items below.



Calc Settings	Includes menu items for configuring calculation settings, such as the display format for calculation results.
System Settings	Includes menu items for configuring calculator operation settings, such as contrast adjustment.
Reset	Includes menu items for performing various types of reset operations.
Get Started	Displays the Get Started screen. For more information, see " <a href="#">Calculator "Get Started" Screen</a> " (page 8).

## Note

- Pressing  $\text{☰}$  while the HOME screen is displayed will display the Get Started screen instead of the SETTINGS menu.
- Depending on the screen displayed by the calculator app, pressing  $\text{☰}$  may not display the SETTINGS menu.

## Changing Calculator Settings

1. Press  $\text{☰}$ , select a calculator app icon, and then press  $\text{OK}$ .
2. Press  $\text{☰}$  to display the SETTINGS menu.



3. Use  $\text{▲}$  and  $\text{▼}$  to select Calc Settings or System Settings, and then press  $\text{OK}$ .
  - This displays a list of setting items included on the selected menu. The screen here shows an example of what appears when [Calc Settings] is selected.

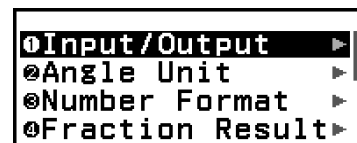

4. Use  $\text{▲}$  and  $\text{▼}$  to highlight the item whose setting you want to change, and then press  $\text{OK}$ .
  - See **"Items and Available Setting Options" (page 24)** for the setting items included for [Calc Settings] and [System Settings].
  - This displays a list of setting options for the item you selected. The screen here shows an example of what appears when [Input/Output] is selected.

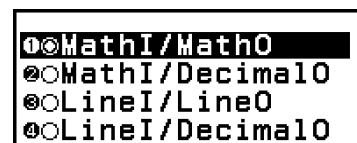

5. Use  $\text{▲}$  and  $\text{▼}$  to highlight the option you want, and then press  $\text{OK}$ .
6. After the setting is the way you want, press  $\text{AC}$ .

## Items and Available Setting Options

"◆" indicates the initial default setting.

---

## Calc Settings > Input/Output

Specifies the format to be used by the calculator for expression input and calculation result output.

MathI/MathO♦	Input: Natural Textbook; Output: Format that includes a fraction, $\sqrt{\quad}$ , and/or $\pi^{*1}$
MathI/DecimalO	Input: Natural Textbook; Output: Converted to decimal value
LineI/LineO	Input: Linear <sup>*2</sup> ; Output: Decimal or fraction
LineI/DecimalO	Input: Linear <sup>*2</sup> ; Output: Converted to decimal value

\*1 Decimal output is applied when these formats cannot be output for some reason.

\*2 All calculations, including fractions and functions are input in a single line. Same output format as that for models without Natural Textbook Display (S-V.P.A.M. models, etc.)

### Input/output format display examples:

MathI/MathO (initial default setting)	$\frac{1}{200}$ $\frac{1}{200}$
--	---------------------------------

MathI/DecimalO (Number Format: Norm1: $1.23 \times 10^{-3}$ )	$\frac{1}{200}$ $5 \times 10^{-3}$
--	------------------------------------

(Number Format: Norm2: 0.00123)	$\frac{1}{200}$ $0.005$
---------------------------------	-------------------------

LineI/LineO	$1 \downarrow 200$ $1 \downarrow 200$
-------------	---------------------------------------

LineI/DecimalO (Number Format: Norm2: 0.00123)	$1 \downarrow 200$ $0.005$
---	----------------------------

---

## Calc Settings > Angle Unit

Degree<sup>◊</sup>; Radian; Gradian

Specifies degree, radian or gradian as the angle unit for value input and calculation result display.

---

## Calc Settings > Number Format

Specifies the number of digits for display of a calculation result.

Fix: The value you specify (from 0 to 9) controls the number of decimal places for displayed calculation results. Calculation results are rounded off to the specified digit before being displayed.

**Example:**  $1 \div 6$

(Fix3:0.123)

$1 \div 6 \uparrow \text{EXE} (\approx)^*$



Sci: The value you specify (from 1 to 10) controls the number of significant digits for displayed calculation results. Calculation results are rounded off to the specified digit before being displayed.

**Example:**  $1 \div 6$

(Sci3 :  $1.23 \times 10^{-1}$ )

$1 \div 6 \uparrow \text{EXE} (\approx)^*$

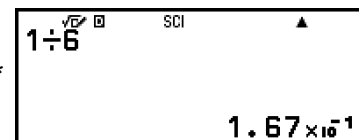

Norm: Displays calculation results in exponential format when they fall within the ranges below.

Norm 1:  $10^{-2} > |x|$ ,  $|x| \geq 10^{10}$ , Norm 2<sup>◊</sup>:  $10^{-9} > |x|$ ,  $|x| \geq 10^{10}$

**Example:**  $1 \div 200$

(Norm1:  $1.23 \times 10^{-3}$ )

$1 \div 200 \uparrow \text{EXE} (\approx)^*$

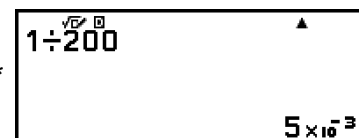

(Norm2:0.00123)

$1 \div 200 \uparrow \text{EXE} (\approx)^*$

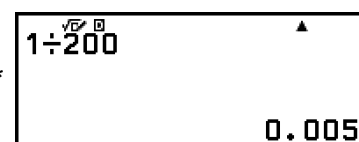

\* Pressing  $\uparrow$  (EXE) ( $\approx$ ) instead of (EXE) after inputting a calculation will display the calculation result in decimal form.

---

## Calc Settings > Fraction Result

Mixed Number; Improper Fraction $\blacklozenge$

Specifies either mixed number or improper fraction for display of fractions in calculation results.

---

## Calc Settings > Complex Result

$a+bi$  $\blacklozenge$ ;  $r\angle\theta$

Specifies either rectangular coordinates or polar coordinates for Complex app calculation results and Equation app polynomial solutions.

### Note

- An  $i$  indicator is displayed at the top of the screen while  $a+bi$  is selected for the Complex Result setting.  $\angle$  is displayed while  $r\angle\theta$  is selected.

---

## Calc Settings > Decimal Mark

Dot $\blacklozenge$ ; Comma

Specifies whether to display a dot or a comma for the calculation result decimal mark. A dot is always displayed during input. When dot is selected as the decimal mark, the separator for multiple results is a comma (,). When comma is selected, the separator is a semicolon (;).

---

## Calc Settings > Digit Separator

On $\blacklozenge$ ; Off

Specifies whether or not a separator character should be used in calculation results.

---

## Calc Settings > $\times 10^{\square}$ Key

This setting specifies the operation of the  $\times 10^{\square}$  key. For more information and example operations, see " $\times 10^{\square}$  Key" (page 39).

$\times 10^{\square}$ (Power)	Pressing $\odot_{\times 10^n}$ produces the same input result as pressing $\otimes \textcircled{1} \textcircled{0} \blacksquare^{\text{P}}$ .
$\times 10^{\square}$ (Sci Notat) <sup>◆</sup>	Pressing $\odot_{\times 10^n}$ inputs the function $\times 10^{\square}$ . This function takes arguments before and after it with the form $a \times 10^n$ ( $n$ is an integer) and returns the result of $10^n$ multiplied by $a$ .

---

## Calc Settings > FORMAT Key

You can toggle what happens when  $\odot_{\text{FORMAT}}$  is pressed between the two operations described below.

$\frac{\square}{\square} \pi \sqrt{\square} \leftrightarrow \text{Decimal}^{\diamond}$	Each press of $\odot_{\text{FORMAT}}$ toggles the displayed calculation result between a form that includes fraction/ $\pi$ / $\sqrt{\square}$ and decimal form. Press $\uparrow \odot_{\text{FORMAT}} (\text{↺})$ to display the FORMAT menu.
Format Menu	Press $\odot_{\text{FORMAT}}$ to display the FORMAT menu. Each press of $\uparrow \odot_{\text{FORMAT}} (\text{↺})$ toggles the displayed calculation result between a form that includes fraction/ $\pi$ / $\sqrt{\square}$ and decimal form.

---

## System Settings > Contrast

See "[Adjusting Display Contrast](#)" (page 15).

---

## System Settings > Auto Power Off

10 Min.<sup>◆</sup>; 60 Min.

Specify the amount of time until Auto Power Off is triggered.

---

## System Settings > MultiLine Font

Normal Font<sup>◆</sup>; Small Font

Specifies the display font size when LineI/LineO or LineI/DecimalO is selected for Input/Output. Up to four lines can be displayed while Normal Font is selected, and up to six lines can be displayed with Small Font.

---



## System Settings > Show Option Num

On<sup>◆</sup>; Off

Specifies whether to show Option Numbers (numbers and symbols to the left of menu items) on menus and dialogs. For details about Option Numbers, see ["Selecting a Menu Item" \(page 17\)](#).

---

## System Settings > QR Code

Specifies the version of the QR Code displayed when   (QR) is pressed.

Version 3: Indicates QR Code Version 3.

Version 11<sup>◆</sup>: Indicates QR Code Version 11.

---

## Reset > Settings & Data

See ["To initialize calculator settings" \(page 29\)](#).

---

## Reset > Variable Memory

See ["Clearing the Contents of All Memories" \(page 45\)](#).

---

## Reset > Initialize All

See ["Initializing the Calculator" \(page 8\)](#).

---

## Get Started

See ["Calculator "Get Started" Screen" \(page 8\)](#).

## To initialize calculator settings

### Important!

- The procedure below initializes all calculator settings, except for Contrast and Auto Power Off. Also clears all data except for variable memory and Ans data.

1. Press , select a calculator app icon, and then press .

- Press  $\text{Ⓜ}$ , and then select [Reset] > [Settings & Data] > [Yes].
  - This displays the HOME screen.

## Using the CATALOG Menu and CATALOG List

### CATALOG Menu

Press  $\text{Ⓜ}$  to display the CATALOG menu like the one shown below. This menu shows categories of the commands, functions, and symbols in accordance with the calculator app you are currently using and the current status (displayed screen or current settings) of the app.

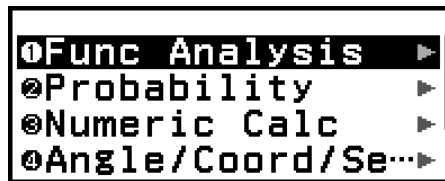

Example: CATALOG menu of the Calculate app

### CATALOG List

Pressing  $\text{Ⓜ}$  ( $\text{Ⓜ}$ ) displays the CATALOG list like the one shown below instead of the CATALOG menu. By pressing the key indicated in a black circle (●) on this list, you can input the command, function or symbol followed by the circle.

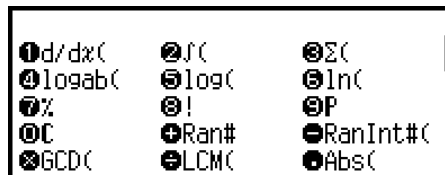

Example: CATALOG list of the Calculate app

### Example Operations

**Example:** To calculate 20% of 30 in the Calculate app

Using the CATALOG menu:

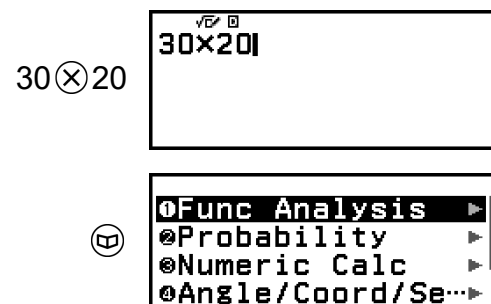

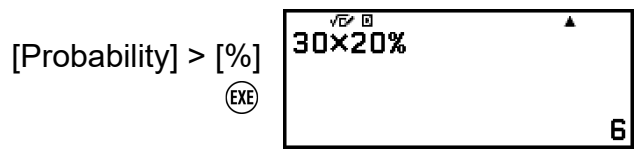

Using the CATALOG list:

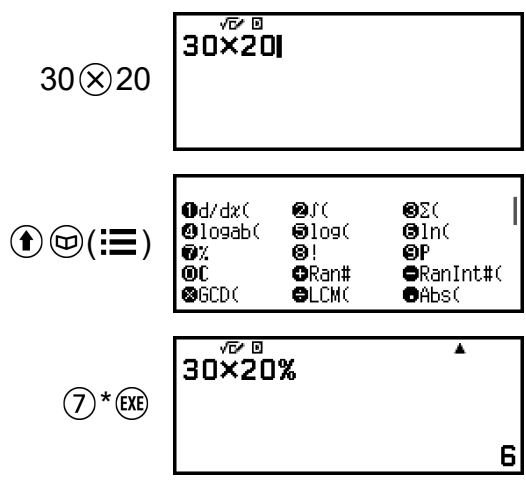

\* Items that appear on the CATALOG list vary depending on the current settings and the app you are using. Because of this, "%" may not always be input with the same key. Be sure to find the function, command or symbol you want to input on the CATALOG list and press the appropriate key.

**Note**

- For information about all commands, functions, and symbols that can be input from the CATALOG menu, see **"Advanced Calculations"** (page 56).
- For information about the commands, functions, and symbols specific to each calculator app, refer to the calculator app descriptions in **"Using Calculator Apps"** (page 76).
- The commands, functions, and symbols contained in the **"Scientific Constants"** (page 67) and **"Unit Conversions"** (page 68) categories in the CATALOG menu are not displayed in the CATALOG list.

## Using the TOOLS Menu

The TOOLS menu that appears when you press  includes menu items for performing functions specific to each calculator app and for configuring settings.

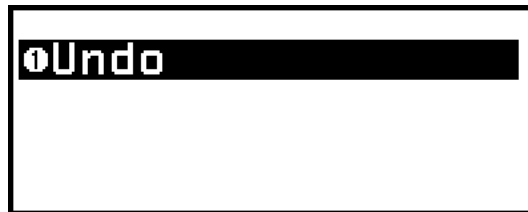

Example: TOOLS menu for the Calculate app

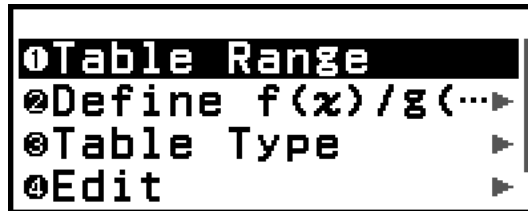

Examples: TOOLS menu for the Table app

### Note

- The menu items below are common to multiple calculator apps.
  - Undo (See "[Undo Operations](#)" (page 35).)

# Inputting Expressions and Values

## Basic Input Rules

When you press  $\text{EXE}$  the priority sequence of the input calculation will be evaluated automatically and the result will appear on the display.

$$4 \times \sin 30 \times (30 + 10 \times 3) = 120$$

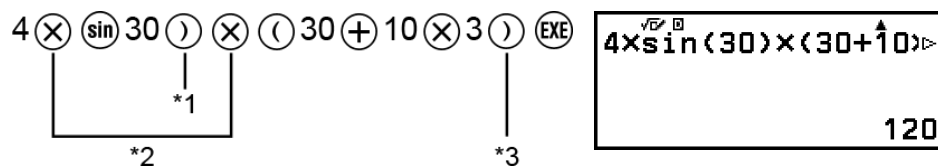

- \*1 Input of the closing parenthesis is required for sin and other functions that include parentheses.
- \*2 These multiplication symbols (x) can be omitted.
- \*3 The closing parenthesis immediately before the  $\text{EXE}$  operation can be omitted.

## Moving the Cursor to the Beginning or End of an Input Expression

While inputting an expression, you can press  $\text{HOME}$  to make the cursor jump to the beginning of the expression or  $\text{END}$  to jump to the end of the expression.

## Input Expression and Calculation Result "More" Indicator (▶, ▶-)

If you see a pointer (▶ or ▶-) symbol on the right side of either an input expression line or calculation result line, it means the displayed line continues to the right. Use  $\text{LEFT}$  and  $\text{RIGHT}$  to scroll the line left and right.

- When you see ▶ at the right end of a calculation result line, you can jump to the end of the result by pressing  $\text{END}$ . To jump to the beginning of a calculation result line, press  $\text{HOME}$ .
- Note that if you want to scroll the input expression while both the ▶ and ▶- indicators are displayed, you will need to press  $\text{ON}$  or  $\text{AC}$  first and then use  $\text{LEFT}$  and  $\text{RIGHT}$  to scroll.

Pol(1.414213562, r=2, θ=0.785398163)

## Parentheses Auto Complete

If you execute a calculation that includes both division and multiplication operations in which a multiplication sign has been omitted, parentheses will be inserted automatically as shown in the examples below.



- When a multiplication sign is omitted immediately before an open parenthesis or after a closing parenthesis.

Example:  $6 \div 2(1 + 2) \rightarrow 6 \div (2(1 + 2))$

- When a multiplication sign is omitted immediately before a variable, a constant, etc.

Example:  $6 \div 2\pi \rightarrow 6 \div (2\pi)$

## Input Limit Indication

The cursor will change shape to  when there are 10 bytes or less of allowed input remaining. If this happens, end calculation input and then press .

# Inputting an Expression Using Natural Textbook Format (MathI/MathO or MathI/DecimalO Only)

---

Expressions that include fractions and/or special functions such as  $\sqrt{\quad}$  can be input in natural textbook format by using templates that appear when certain keys are pressed, or when you input certain functions from the CATALOG menu.

**Example:**  $3\frac{1}{2} + 5\frac{3}{2}$

1. Press   (.

- This inputs a mixed number template.

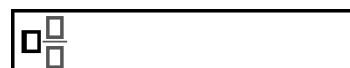

2. Input values into the integer, numerator, and denominator areas of the template.

$3\frac{1}{2}$



# Basic Calculations

## Arithmetic Calculations

Use the  $\oplus$ ,  $\ominus$ ,  $\otimes$ , and  $\odiv$  keys to perform arithmetic calculations.

**Example:**  $7 \times 8 - 4 \times 5 = 36$

$7 \otimes 8 \ominus 4 \otimes 5 \text{ EXE}$

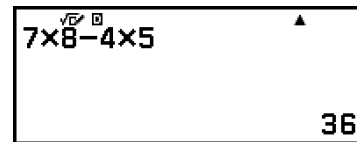

## Fraction Calculations

Note that the input method for fractions depends on the current Input/Output setting on the SETTINGS menu.

To input  $\frac{7}{3}$  (improper fraction)

(Input/Output: MathI/MathO or MathI/DecimalO)

$\text{[Frac]} 7 \text{[Down]} 3$ or $7 \text{[Frac]} 3$	$\frac{7}{3}$
--	---------------

(Input/Output: LineI/LineO or LineI/DecimalO)

$7 \text{[Frac]} 3$	$\begin{array}{ccc} & 7 & \text{[Frac]} & 3 \\ & \swarrow & & \searrow \\ \text{(a)} & & & \text{(b)} \end{array}$
---------------------	--

(a) Numerator, (b) Denominator

To input  $2 \frac{1}{3}$  (mixed number)

(Input/Output: MathI/MathO or MathI/DecimalO)

$\text{[Up]} \text{[Frac]} (\text{[Frac]} 1) 2 \text{[Down]} 3$	$2 \frac{1}{3}$
---	-----------------

(Input/Output: LineI/LineO or LineI/DecimalO)

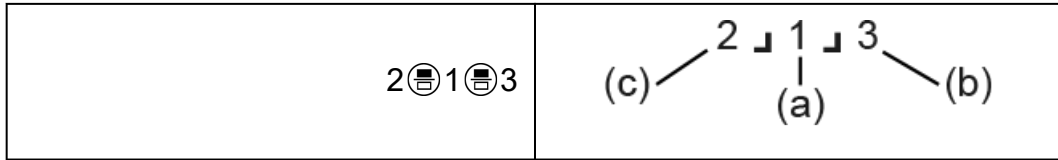

(a) Numerator, (b) Denominator, (c) Integer Part

**Example:**  $\frac{2}{3} + 1\frac{1}{2} = \frac{13}{6}$

(Input/Output: MathI/MathO)

$2 \frac{1}{3} + 1 \frac{1}{2}$  (using fraction format keys)



(Input/Output: LineI/LineO)

$2 \frac{1}{3} + 1 \frac{1}{2}$  (using line format keys)

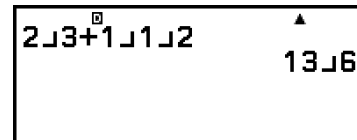

**Note**

- Fractions in calculation results are displayed after being reduced to their lowest terms.

To convert a calculation result format to improper fraction or mixed number, press  $\uparrow$  (FORMAT) (↺). For more information, see **"Improper Fraction and Mixed Number Conversion"** (page 53).

**Fraction Format Calculation Results**

A calculation result whose total number of digits used in the mixed number (including integer, numerator, denominator, and separator symbol  $\frac{\_}{\_}$ ) is greater than 10 cannot be displayed using fraction format. In this case, the calculation result is displayed as a decimal value.

**Example 1:**  $1 \frac{1}{1} \frac{123456}{123456} = 123457 \frac{1}{123456}$

(Input/Output: LineI/LineO)

$1 \frac{1}{1} \frac{123456}{123456}$  (using line format keys)



Since the total number of digits of the value  $1 \frac{1}{1} \frac{123456}{123456}$  is 10, the result is displayed as a fraction value.

**Example 2:**  $1 \frac{1}{1} \frac{1234567}{1234567} (= 1234568 \frac{1}{1234567}) = 1.00000081$

(Input/Output: LineI/LineO)

1  $\frac{\square}{\square}$  1  $\frac{\square}{\square}$  1234567  $\frac{\square}{\square}$  EXE



1  $\frac{\square}{\square}$  1  $\frac{\square}{\square}$  1234567  
1.00000081

Since the total number of digits of the value  $1 \frac{\square}{\square} 1 \frac{\square}{\square} 1234567$  is 11, the result is displayed as a decimal value.

### Note

- Mixing fractions and decimal values in a calculation while something other than MathI/MathO is selected will cause the result to be displayed as a decimal value.

## Powers, Power Roots, and Reciprocals

Use the keys below to input power functions, power root functions, and reciprocal function.

Power functions:  $\frac{\square}{\square}$  (square),  $\frac{\square}{\square}$  ( $n^{\text{th}}$  power)

Power root functions:  $\sqrt{\square}$  (square root),  $\sqrt[n]{\square}$  ( $n^{\text{th}}$  root)

Reciprocal function:  $\frac{\square}{\square}$  ( $\square^{-1}$ )

**Example 1:**  $(5^2)^3 = 15625$

( 5  $\frac{\square}{\square}$  )  $\frac{\square}{\square}$  3 EXE



$(5^2)^3$   
15 625

**Example 2:**  $(1 + 1)^{2+2} = 16$

( 1 + 1 )  $\frac{\square}{\square}$  2 + 2 EXE

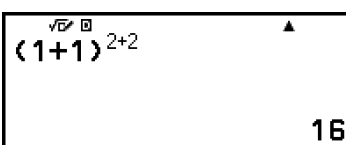

$(1+1)^{2+2}$   
16

**Example 3:**  $\sqrt{2} \times 3 = 3\sqrt{2} = 4.242640687\dots$

(Input/Output: MathI/MathO)

$\sqrt{\square}$  2 >  $\times$  3 EXE



$\sqrt{2} \times 3$   
 $3\sqrt{2}$

(Input/Output: LineI/LineO)

$\sqrt{\square} 2 \text{ ) } \times 3 \text{ EXE}$

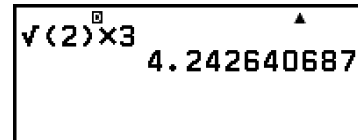

**Example 4:**  ${}^5\sqrt{32} = 2$

(Input/Output: MathI/MathO)

$\uparrow \sqrt{\square} (\sqrt{\square}) 5 > 32 \text{ EXE}$



(Input/Output: LineI/LineO)

$5 \uparrow \sqrt{\square} (\sqrt{\square}) 32 \text{ ) EXE}$

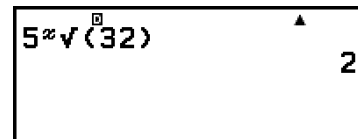

**Example 5:**  $10^{-1} = \frac{1}{10}$

(Input/Output: MathI/MathO)

$10 \uparrow \square (\square^{-1}) \text{ EXE}$



### $\times 10^\square$ Key

Pressing  $\times 10^\square$  inputs " $\times 10^\square$ " or " $\times 10^\square$ " in accordance with the current  $\text{MODE}$  – [Calc Settings] > [ $\times 10^\square$  Key] setting.

- When " $\times 10^\square$  (Sci Notat)" is selected for [ $\times 10^\square$  Key] (initial default): Pressing  $\times 10^\square$  inputs the function  $\times 10^\square$ . This function takes arguments before and after it with the form  $a \times 10^n$  ( $n$  is an integer) and returns the result of  $10^n$  multiplied by  $a$ .
- When " $\times 10^\square$  (Power)" is selected for [ $\times 10^\square$  Key]: Pressing  $\times 10^\square$  produces the same input result as pressing  $\times 1 \text{ 0 } \square$ , which inputs " $\times 10^\square$ ".

**To calculate**  $\frac{4 \times 10^7}{3 \times 10^8}$

When " $\times 10^\square$  (Sci Notat)" is selected for [ $\times 10^\square$  Key] (initial default):

**Example 1:** (Input/Output: MathI/MathO)

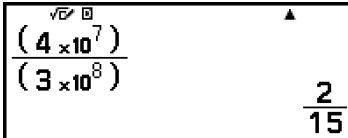
$$4 \times 10^7 \div 3 \times 10^8 \text{ EXE}$$

**Example 2:** (Input/Output: LineI/LineO)

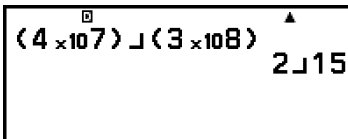
$$4 \times 10^7 \div 3 \times 10^8 \text{ EXE}$$

When " $\times 10^{\square}$  (Power)" is selected for [ $\times 10^{\square}$  Key]:

**Example 3:** (Input/Output: MathI/MathO)

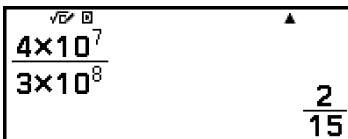
$$\div 4 \times 10^7 \vee 3 \times 10^8 \text{ EXE}^{*1}$$

**Example 4:** (Input/Output: LineI/LineO)

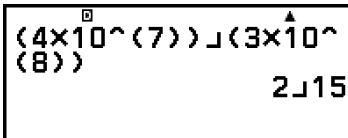
$$(\div 4 \times 10^7) \vee (\div 3 \times 10^8) \text{ EXE}^{*2}$$

\*1 With these settings ( $\times 10^{\square}$  Key:  $\times 10^{\square}$  (Power), Input/Output: MathI/MathO), executing  $4 \times 10^7 \div 3 \times 10^8$  causes the calculation to be performed sequentially from left to right, which produces a different calculation result than the one in the above example (using fractions). To obtain the same calculation result, each term needs to be enclosed in parentheses:  $(4 \times 10^7) \div (3 \times 10^8)$ .

\*2 With these settings ( $\times 10^{\square}$  Key:  $\times 10^{\square}$  (Power), Input/Output: LineI/LineO), executing  $4 \times 10^{(7)} \div 3 \times 10^{(8)}$  (or  $4 \times 10^{(7)} \div 3 \times 10^{(8)}$ ) causes the calculation to be performed sequentially from left to right, which produces a different calculation result than the example 3. To obtain the same calculation result, each term needs to be enclosed in parentheses as the example 4.

### Note

- When " $\times 10^{\square}$  (Sci Notat)" is selected for [ $\times 10^{\square}$  Key], parentheses will be inserted automatically as shown in the example below (The same applies to Example 1 and Example 2 above).

$$1 + 1 \times 10^{-2}$$

Note, however, that parentheses will not be inserted automatically if you input the sexagesimal symbol ( $\square$ ) immediately after  $\times 10^{\square}$ .

## $\sqrt{\quad}$ Form Calculation Range

The allowable display ranges of the  $\sqrt{\quad}$  form calculation result are shown below.

$$\pm a\sqrt{b}, \pm d \pm a\sqrt{b}, \pm \frac{a\sqrt{b}}{c} \pm \frac{d\sqrt{e}}{f}$$

$$1 \leq a < 100, 1 < b < 1000, 1 \leq c < 100$$

$$0 \leq d < 100, 0 \leq e < 1000, 1 \leq f < 100$$

### Example:

- $10\sqrt{2} + 15 \times 3\sqrt{3} = 45\sqrt{3} + 10\sqrt{2} \dots$  Displayed in  $\sqrt{\quad}$  form
- $99\sqrt{999} (= 297\sqrt{111}) = 3129.089165 \dots$  Displayed as a decimal value

## Pi, Natural Logarithm Base $e$

### Pi

Input  $\pi$  by pressing  $\uparrow$   $\textcircled{7}$  ( $\pi$ ).

$\pi$  is displayed as 3.141592654, but  $\pi = 3.1415926535897932384626$  is used for internal calculations.

### Natural Logarithm Base $e$

Input  $e$  by pressing  $\uparrow$   $\textcircled{8}$  ( $e$ ).

Natural Logarithm Base  $e$  is displayed as 2.718281828, but  $e = 2.7182818284590452353602$  is used for internal calculations.

# Calculation History and Replay

## Calculation History

An ▲ and/or ▼ at the top of the screen indicates more calculation history content above and/or below. You can scroll through calculation history contents using ▲ and ▼.

### Apps that support calculation history:

Calculate, Complex, Base-N

#### Example

$$2 + 2 = 4$$

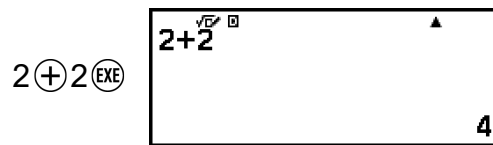

$$3 + 3 = 6$$

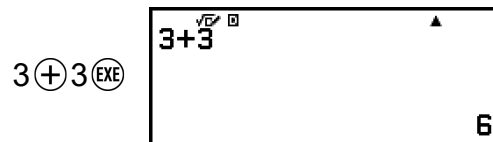

▲  
(Scrolls back.)



#### Note

- Calculation history data is all cleared whenever you press ⏻ or ⏪, when you change the Input/Output setting, or whenever you perform a Reset operation ("Settings & Data" or "Initialize All").

## Replay

While a calculation result is on the display, you can press ⏪, ⏩, or ⏴ to edit the expression you used for the previous calculation.

#### Example

$$4 \times 3 + 2 = 14$$

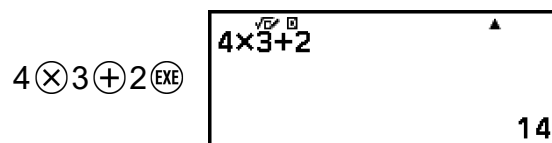

$$4 \times 3 - 7 = 5$$

(Continuing)  $\leftarrow$   $\otimes$   $\otimes$   $\ominus$  7  $\text{EXE}$

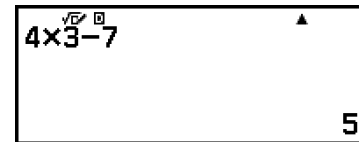

### Note

- If  $\blacktriangleleft$  (left) or  $\blacktriangleright$  (right) is displayed on either end or both ends of a calculation result line, you can use  $\leftarrow$  and  $\rightarrow$  to scroll the line left and right. If this happens, press  $\rightarrow$  or  $\text{AC}$  first, and then use  $\leftarrow$  and  $\rightarrow$  to edit the expression.

## Using Memory Functions

### Answer Memory (Ans)

The last calculation result obtained is stored in Ans (answer) memory.

### Using Ans Memory to Perform a Series of Calculations

**Example:** To divide the result of  $3 \times 4$  by 30

$$3 \times 4 \text{ EXE}$$

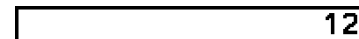

(Continuing)  $\div$  30  $\text{EXE}$

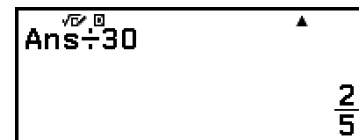

### Inputting Ans Memory Contents into an Expression

**Example:** To perform the calculations shown below:

$$123 + 456 = 579 \quad 789 - 579 = 210$$

A diagram showing two calculations. The first is  $123 + 456 = 579$  and the second is  $789 - 579 = 210$ . A horizontal line with an upward-pointing arrow connects the result  $579$  of the first calculation to the  $579$  in the second calculation's expression.

$$123 \oplus 456 \text{ EXE}$$

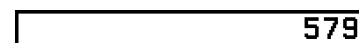

(Continuing) 789  $\ominus$   $\text{Ans}$   $\text{EXE}$

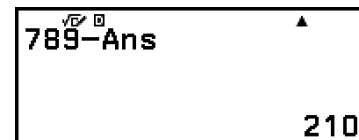

### Variables (A, B, C, D, E, F, x, y, z)

You can store values to variables and use the variables in calculations.

## Variable List Screen

A=36	B=123 456
C=1 234 567	D=12 345 678
E=123 456 789	F=1 234 567 890
x=1.2345×10 <sup>10</sup>	y=0
z=0	

Pressing  $\left(\frac{\square}{\square}\right)$  displays a screen that shows the values currently stored to variables A, B, C, D, E, F, x, y, and z. On this screen, values are always displayed using the "Norm 1" Number Format. To close the screen, press  $\left(\frac{\square}{\square}\right)$  or  $\left(\frac{\square}{\square}\right)$ .

**Example 1:** To store the result of  $3 + 5$  to variable A

1. Execute the calculation.

$3 + 5$   $\left(\frac{\square}{\square}\right)$   $\left(\frac{\square}{\square}\right)$



The calculator screen displays the expression 3+5 and the result 8. The number format is Norm 1, indicated by the 'D' in the top right corner.

2. Press  $\left(\frac{\square}{\square}\right)$ , and then select [A=] > [Store].

- This stores the result of  $3 + 5$  (which is 8) to variable A.

3. Press  $\left(\frac{\square}{\square}\right)$ .



The variable list screen shows A=8 and B=0.

**Example 2:** To change the contents of variable A to 1

1. Press  $\left(\frac{\square}{\square}\right)$ , and then highlight [A=].



The variable list screen shows A=8 and B=0. The 'A=8' entry is highlighted with a black bar.

2. Press  $\left(\frac{\square}{\square}\right)$ .

- This displays the editing screen with 1 entered.



The editing screen shows A=1 with a cursor at the end of the number.

3. Press  $\left(\frac{\square}{\square}\right)$ .



The variable list screen shows A=1 and B=0.

### Note

- In place of the operation in step 2 above, you can press  $\left(\frac{\square}{\square}\right)$  and then select [Edit]. This displays the editing screen with nothing input. Input the value you want and then press  $\left(\frac{\square}{\square}\right)$ .
- Depending on the operation you were performing immediately before pressing  $\left(\frac{\square}{\square}\right)$  to display the variable list screen, you cannot change the contents of a variable from the variable list screen. In this case, a lock (🔒) icon appears when you highlight a

variable on the variable list screen, indicating that the highlighted variable cannot be edited.

For example, if you press  $\text{2ND}$  while inputting data in the Statistics Editor of the **Statistics app (page 76)**, the  icon appears on the right of the highlighted variable, which means the variable cannot be edited.

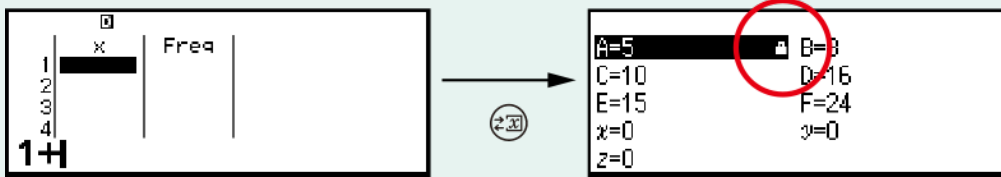

On the Statistics Editor, press  $\text{2ND}$  to stop inputting data and then press  $\text{2ND}$ . The  icon disappears, and you will be able to edit the variable.

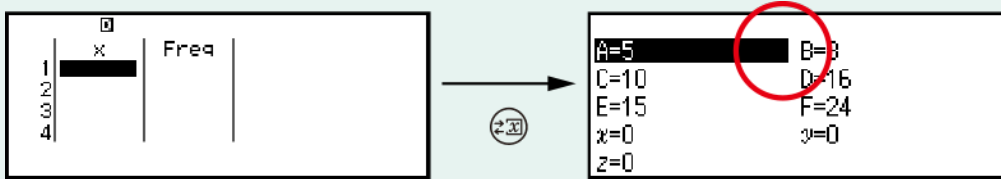

**Example 3:** To recall the contents of variable A  
(Continuing from step 2 of Example 1)

1. Press  $\text{2ND}$ , and then select  $[A=] > [\text{Recall}]$ .
  - This inputs "A".

A

2. Press  $\text{EXE}$ .
  - This recalls the value of variable A.

A 8

**Example 4:** To multiply the contents of variable A by 10  
(Continuing from step 2 of Example 1)

$\text{2ND} \text{ 4 } (A) * \text{ 10 } \text{EXE}$



A $\times$ 10 80

\* Input a variable as shown here: press  $\text{2ND}$  and then press the key that corresponds to the desired variable name. To input  $x$  as the variable name, you can press  $\text{2ND} \text{ 0 } (x)$  or  $\text{X}$ .

## Clearing the Contents of All Memories

Ans memory and variable contents are retained even if you press  $\text{AC}$ , change the calculator app, or turn off the calculator.

Perform the procedure below when you want to clear the contents of all memories.

1. Press , select a calculator app icon, and then press .
2. Press , and then select [Reset] > [Variable Memory] > [Yes].

# Changing Calculation Result Format

## Toggling Calculation Results between Standard (Fraction, $\pi$ , $\sqrt{\quad}$ Form) and Decimal

Each press of  $\text{FORMAT}$  while a calculation result is displayed toggles the result between the following two forms:

- a form that includes fraction,  $\pi$ , or  $\sqrt{\quad}$  (standard format)
- decimal form

### Note

- Toggling calculation result display formats by pressing only  $\text{FORMAT}$  is supported when " $\frac{\square}{\square}\pi\sqrt{\square} \leftrightarrow \text{Decimal}$ " (initial default) is selected for the FORMAT Key setting on the SETTINGS menu. If "Format Menu" is selected for the FORMAT Key setting, press  $\uparrow \text{FORMAT} \text{ (}\text{C}\text{)}$ .
- Conversion to standard format that includes  $\sqrt{\quad}$  or  $\pi$  is possible when MathI/MathO or MathI/DecimalO is selected for the Input/Output setting on the SETTINGS menu.

**Example:**  $2\sqrt{2} = 2.828427125$  (Input/Output: MathI/MathO)

The diagram illustrates the process of toggling the calculation result format for  $2\sqrt{2}$  on a calculator. It shows three stages of the display:

- Initial Input:** The user enters  $2 \times \sqrt{\quad} 2 \text{ EXE}$ . The display shows  $2 \times \sqrt{\quad}$  at the top and  $2\sqrt{2}$  at the bottom.
- First Toggle:** Pressing the  $\text{FORMAT}$  key toggles the result to decimal form. The display shows  $2 \times \sqrt{\quad}$  at the top and  $2.828427125$  at the bottom.
- Second Toggle:** Pressing the  $\text{FORMAT}$  key again toggles the result back to standard form. The display shows  $2 \times \sqrt{\quad}$  at the top and  $2\sqrt{2}$  at the bottom.

To obtain a decimal value calculation result while MathI/MathO or LineI/LineO is selected

Press  $\uparrow \text{EXE} (\approx)$  instead of  $\text{EXE}$  after inputting a calculation.

# Changing the Display Format of Calculation Results (FORMAT Menu)

Pressing  $\uparrow$   $\text{FORMAT}$   $\left(\frac{\square}{\square}\right)$ \* displays the FORMAT menu, which you can use to change the display format of calculation results.

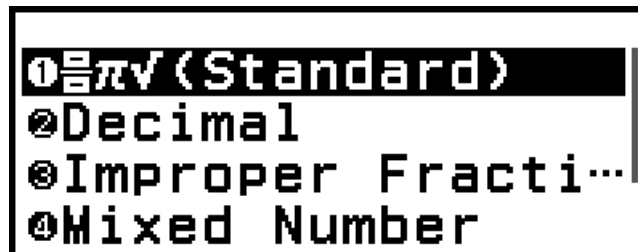

\* When " $\frac{\square}{\square}\pi\sqrt{\square} \leftrightarrow$  Decimal" (initial default) is selected for the FORMAT Key setting on the SETTINGS menu. If "Format Menu" is selected for the FORMAT Key setting, press  $\text{FORMAT}$ .

## FORMAT Menu List

This menu item:	Converts to this format:
$\frac{\square}{\square}\pi\sqrt{\square}$ (Standard)	Standard (Includes fraction, $\pi$ , $\sqrt{\square}$ formats.)
Decimal	Decimal
Prime Factor	Prime factorization
Recurring Decimal	Recurring decimal
Rectangular Coord	Rectangular coordinates
Polar Coord	Polar coordinates
Improper Fraction	Improper fraction
Mixed Number	Mixed number
Standard Form	$a \times 10^n$
Sexagesimal	Degree, minute, second (Sexagesimal)

## Note

- The menu items that appear when  $\uparrow$  (FORMAT) (↺) is pressed depend on the currently displayed calculation result. Also, if a calculation result that cannot be converted is displayed, the menu will not appear when you press  $\uparrow$  (FORMAT) (↺).

## Conversion Sample Operation

**Example:**  $3 \div 2 = \frac{3}{2} = 1.5 = 1 \frac{1}{2}$

In this example, we will convert a calculation result displayed as an improper fraction to a decimal value and then to a mixed number. Finally, we will cancel the conversion and go back to the original calculation result. (Input/Output: MathI/MathO, Fraction Result: Improp Fraction)

- Execute the calculation  $3 \div 2$ .

$3 \div 2$  (EXE)



The calculator display shows the expression  $3 \div 2$  at the top left. At the bottom right, the result is displayed as the improper fraction  $\frac{3}{2}$ . The display also shows a small triangle cursor at the top right and the text  $\sqrt{\square}$  at the top left.

- To convert the calculation result to a decimal value, press  $\uparrow$  (FORMAT) (↺), select [Decimal], and then press (EXE).



The calculator display shows the expression  $3 \div 2$  at the top left. At the bottom right, the result is displayed as the decimal value 1.5. The display also shows a small triangle cursor at the top right and the text  $\sqrt{\square}$  at the top left.

- To convert the calculation result to a mixed number, press  $\uparrow$  (FORMAT) (↺), select [Mixed Number], and then press (EXE).



The calculator display shows the expression  $3 \div 2$  at the top left. At the bottom right, the result is displayed as the mixed number  $1 \frac{1}{2}$ . The display also shows a small triangle cursor at the top right and the text  $\sqrt{\square}$  at the top left.

- To cancel conversion, press (EXE).
  - This displays the original calculation result from step 1.



The calculator display shows the expression  $3 \div 2$  at the top left. At the bottom right, the result is displayed as the improper fraction  $\frac{3}{2}$ . The display also shows a small triangle cursor at the top right and the text  $\sqrt{\square}$  at the top left.

## Standard and Decimal Conversion

Standard is a format that displays a calculation result in a form that includes a fraction,  $\sqrt{\quad}$ , or  $\pi$  when possible. Decimal is a format that displays the calculation result as a decimal value.



**Example:** To perform prime factorization on 1014

1014 (EXE)



↑ (FORMAT) (↺) – [Prime Factor]



### Note

- The types of values described below cannot be factored, even if they have 10 or fewer digits.
  - One of the prime factors of the value is 1,018,081 or greater.
  - Two or more of the prime factors of the value have more than three digits.
- The part that cannot be factored is enclosed in parentheses on the display.

**Example:**  $2036162 = 2 \times (1018081)^*$

\*1018081 =  $1009^2$

2036162 (EXE)

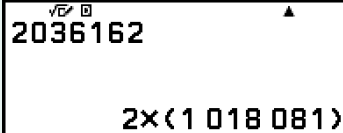

↑ (FORMAT) (↺) – [Prime Factor]

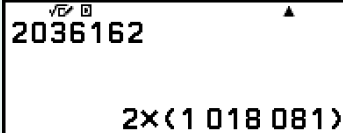

## Recurring Decimal Conversion (Recurring Decimal Calculations)

Your calculator lets you convert a calculation result to recurring decimal format in the Calculate app when possible. It also makes it possible for you to input a recurring decimal value and perform a calculation.

### Converting a Calculation Result to a Recurring Decimal Value

To convert a calculation result to a recurring decimal value, press ↑ (FORMAT) (↺), and then select [Recurring Decimal] from the FORMAT menu that appears. For the actual operation, see "[Recurring Decimal Calculation Example](#)" (page 52).

### Inputting a Recurring Decimal

To input a recurring decimal value, use the CATALOG menu item shown below.

Ⓜ – [Numeric Calc] > [Recurring Decimal]

For the actual operation, see "[Recurring Decimal Calculation Example](#)" (page 52).

### Important!

- If the value starts with an integer part (like: 12.3123123...), do not include the integer part when inputting the period ( $12.\dot{3}1\dot{2}$ ).
- Recurring decimal input is possible only when MathI/MathO or MathI/DecimalO is selected for Input/Output on the SETTINGS menu.

## Recurring Decimal Calculation Example

To calculate  $3.\dot{0}2\dot{1} + 0.\dot{3}1\dot{2}$  (Input/Output: MathI/MathO)

1. Use the following operation to input the calculation expression.

$\text{[MODE]} - [\text{Numeric Calc}] > [\text{Recurring Decimal}]$   
 $3 \text{ [.] } 021 \text{ [.] } +$

$\text{[MODE]} - [\text{Numeric Calc}] > [\text{Recurring Decimal}]$   
 $312 \text{ [.] } 312 \text{ [.] } +$

- This displays the calculation result as a fraction.

2. Press  $\text{[MODE]} \text{ [FORMAT]} \text{ [RECALL]}$ , and then select [Recurring Decimal].

- This changes the result format to recurring decimal.

- To return the calculation result to a fraction, select  $\text{[MODE]} \text{ [FORMAT]} \text{ [RECALL]} - [\text{Standard}]$  (Standard)].

### Note

- Only a calculation result that satisfies the conditions below can be displayed as a recurring decimal.
  - The total number of digits used in the mixed number (including integer, numerator, denominator, and separator symbol) must be no more than 10.
  - The data size of the value when displayed as a recurring decimal must be no larger than 99 bytes, calculated as: [number of digits (1 byte each)] + [1 byte for the decimal point] + [3 bytes for recurring decimal management code]. For example, the data size of  $0.\dot{1}2\dot{3}$  would be 4 bytes for digits, 1 byte for the decimal point, and 3 bytes for recurring decimal management code, for a total of 8 bytes.

# Rectangular and Polar Coordinate Conversion

---

You can convert a complex number calculation result to rectangular coordinates ( $\uparrow$   $\text{FORMAT}$ ) ( $\text{FORMAT}$ ) ( $\text{FORMAT}$ ) – [Rectangular Coord]) or polar coordinates ( $\uparrow$   $\text{FORMAT}$ ) ( $\text{FORMAT}$ ) ( $\text{FORMAT}$ ) – [Polar Coord]). This conversion operation can be performed in either of the following cases.

- While an Equation app higher-order equation solution is displayed (provided that On is selected for the  $\text{FORMAT}$  – [Complex Roots] setting of the Equation app)
- While a Complex app calculation result is displayed

For an actual sample conversion operation, see the sections below.

["Converting a Complex Number Solution to Rectangular or Polar Coordinates" \(page 102\)](#)

["Converting a Complex Number Calculation Result to Rectangular or Polar Coordinates" \(page 113\)](#)

# Improper Fraction and Mixed Number Conversion

---

You can convert the currently displayed fraction or decimal value (decimal value that is convertible to a fraction by this calculator) calculation result to a mixed number or an improper fraction.

**Example 1:**  $\frac{13}{4} = 3 \frac{1}{4}$

(Input/Output: MathI/MathO, Fraction Result: Improp Fraction)

$13 \text{ } \text{FORMAT} \text{ } 4 \text{ } \text{EXE}$   $\frac{13}{4}$

$\uparrow \text{FORMAT} \text{ } \text{FORMAT}$  – [Mixed Number]  $3 \frac{1}{4}$

$\uparrow \text{FORMAT} \text{ } \text{FORMAT}$  – [Improper Fraction]  $\frac{13}{4}$

**Example 2:**  $3.25 = \frac{13}{4} = 3 \frac{1}{4}$  (Input/Output: LineI/LineO)

$3 \text{ } \text{FORMAT} \text{ } 25 \text{ } \text{EXE}$  3.25

$\uparrow \text{FORMAT} \text{ } \text{FORMAT}$  – [Improper Fraction] 13 J 4

$\uparrow \text{FORMAT} \text{ } \text{FORMAT}$  – [Mixed Number] 3 J 1 J 4

# Standard Form ( $a \times 10^n$ )

You can convert the currently displayed calculation result to a  $\times 10^n$  format.

**Example:**  $123456 = 1.23456 \times 10^5$

123456  $\text{EXE}$  123 456

$\uparrow$   $\text{FORMAT}$   $\text{↺}$  – [Standard Form] 1.23456  $\times 10^5$

# Sexagesimal Conversion (Degree, Minute, Second Calculations)

You can convert a decimal value calculation result to a sexagesimal value.

## Converting a Decimal Value Calculation Result to a Sexagesimal Value

**Example:**  $1.25 = 1^\circ 15' 0''$

1  $\text{.}$  25  $\text{EXE}$  1.25 5  
4

$\uparrow$   $\text{FORMAT}$   $\text{↺}$  – [Sexagesimal] 1.25 1° 15' 0''

## Inputting and Calculating with a Sexagesimal Value

In addition to converting a displayed value to a sexagesimal value, you can also input sexagesimal values and use them in calculations.

The syntax below is for inputting a sexagesimal value:



{degrees}  $\uparrow$   $\oplus$  (°) {minutes}  $\uparrow$   $\oplus$  (') {seconds}  $\uparrow$   $\oplus$  (")

Note that you must always input something for the degrees and minutes, even if they are zero.

**Example:** To perform the calculation  $2^\circ 20' 30'' + 9' 30''$ . Next, convert the calculation result to a decimal value.



2  $\uparrow$   $\oplus$  (°) 20  $\uparrow$   $\oplus$  (') 30  $\uparrow$   $\oplus$  (") 0  $\uparrow$   $\oplus$  (°) 9  $\uparrow$   $\oplus$  (') 30  $\uparrow$   $\oplus$  (")  $\text{EXE}$  2° 20' 30" + 0° 9' 30" 2° 30' 0"

(Convert to a decimal value.)

   – [Decimal]

$2^{\circ} 20' 30'' + 0^{\circ} 9' 30''$   
2.5

(Return to sexagesimal display.)

   – [Sexagesimal]

$2^{\circ} 20' 30'' + 0^{\circ} 9' 30''$   
2° 30' 0"

# Advanced Calculations

---

This section describes commands, functions, and symbols that are common to all of the calculator apps. The order used here to present commands, functions, and symbols is the same order in which they are displayed on the CATALOG menu that appears when you press  $\text{Ⓜ}$ .

## Note

---

- There are also calculator app-specific CATALOG menu items, which are not shown here. See the chapter for each calculator app for more information about app-specific menu items.
- Depending on the calculator app you are using and the screen displayed by the calculator app, you may not be able to input some commands, functions, or symbols. Commands, functions, and symbols that cannot be input do not appear on the CATALOG menu.
- The commands, functions, and symbols described here are not available in the Base-N app.
- Pressing  $\text{⬆} \text{Ⓜ} (\text{≡})$  displays a list of up to 15 commands, functions, and symbols per a screen (CATALOG list) instead of the CATALOG menu. For more information, see "[CATALOG List](#)" (page 30).

## Function Analysis

---

This section explains commands and functions that you can input after performing the operation:  $\text{Ⓜ} - [\text{Func Analysis}]$ .

### Derivative(d/dx)

Derivative(d/dx) obtains the approximate differential coefficient at the specified  $x$ -coordinate ( $a$ ) in the input  $f(x)$  expression.

## Note

---

- This function can be used with any of the following calculator apps: Calculate, Statistics, Table, Equation, Inequality, Distribution, Matrix, Vector, Spreadsheet, Ratio.

### Input Syntax

The input syntax depends on the Input/Output setting on the SETTINGS menu, as shown in the table below.



### Note

- This function can be used with any of the following calculator apps: Calculate, Statistics, Table, Equation, Inequality, Distribution, Matrix, Vector, Spreadsheet, Ratio.

## Input Syntax

The input syntax depends on the Input/Output setting on the SETTINGS menu, as shown in the table below.

Input/Output setting	Input Syntax
MathI/MathO or MathI/DecimalO	$\int_a^b f(x)dx$
LineI/LineO or LineI/DecimalO	$\int (f(x), a, b, tol)^*$

\* *tol* specifies tolerance, which becomes  $1 \times 10^{-10}$  when nothing is input for *tol*.

## Integration Calculation Precautions

- When using a trigonometric function in  $f(x)$ , specify "Radian" as Angle Unit on the SETTINGS menu.
- A smaller *tol* value increases precision, but it also increases calculation time. When specifying *tol*, use a value that is  $1 \times 10^{-22}$  or greater.
- Depending on the content of  $f(x)$ , positive and negative values within the region of integration or the region of integration, large error may result in calculated integration values. (Examples: When there are parts with discontinuous points or abrupt change. When the integration interval is too wide.) In such cases, dividing the integration interval into multiple parts and then performing calculations may improve calculation accuracy.

## Integration Calculation Example

$$\int (\ln(x), 1, e) = 1 \quad (\text{tol specification omitted.})$$

(Input/Output: MathI/MathO)

⊞ – [Func Analysis] > [Integration(∫)]  
 ↑ (log=) (ln) (x) ) ↓ 1 ^ ↑ 8 (e) EXE

The screenshot shows a calculator interface with the following elements:
 

- Top status bar:  $\sqrt{\square}$ ,  $\square$ , and  $\blacktriangle$ .
- Main display:  $\int_1^e \ln(x) dx$
- Bottom right corner:  $1$



$\text{☞}$  – [Func Analysis] > [Summation( $\Sigma$ )]  
 $\text{ⓧ} \text{+} 1 \text{⏏} \text{)} \text{,} 1 \text{⏏} \text{)} \text{,} 5 \text{⏏} \text{) EXE}$

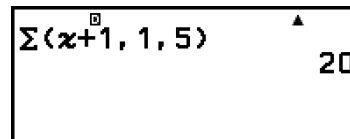

## Logarithm(logab), Logarithm(log)

Use  $\text{⏏} \text{ⓧ}^2 \text{(log)}$  or  $\text{☞}$  – [Func Analysis] > [Logarithm(log)] to input  $\log_{ab}$  as  $\log(a, b)$ . Base 10 is the initial default setting if you do not input anything for  $a$ .

**Example 1:**  $\log_{10}1000 = \log 1000 = 3$

$\text{⏏} \text{ⓧ}^2 \text{(log)} 1000 \text{⏏} \text{) EXE}$

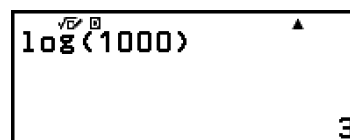

**Example 2:**  $\log_2 16 = 4$

$\text{⏏} \text{ⓧ}^2 \text{(log)} 2 \text{⏏} \text{)} \text{,} 16 \text{⏏} \text{) EXE}$

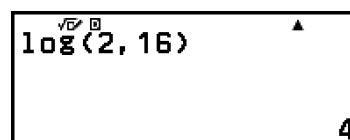

The  $\text{ⓧ}^2 \text{(log)}$  key (or  $\text{☞}$  – [Func Analysis] > [Logarithm(logab)]) also can be used for input, but only while MathI/MathO or MathI/DecimalO is selected for Input/Output on the SETTINGS menu. In this case, you must input a value for the base.

**Example 3:**  $\log_2 16 = 4$

$\text{ⓧ}^2 \text{(log)} 2 \text{>} 16 \text{ EXE}$

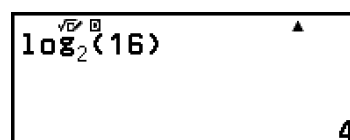

## Natural Logarithm

Use  $\text{⏏} \text{ⓧ}^2 \text{(ln)}$  or  $\text{☞}$  – [Func Analysis] > [Natural Logarithm] to input "ln".

**Example:**  $\ln 90 (= \log_e 90) = 4.49980967$

$\text{⏏} \text{ⓧ}^2 \text{(ln)} 90 \text{⏏} \text{) EXE}$

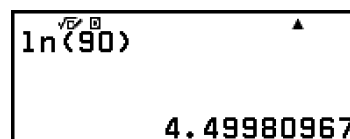

## Probability

This section explains commands and functions that you can input after performing the operation:  $\text{☞}$  – [Probability].



Permutations:

$$\text{[Probability]} > [\text{Permutation}(P)]$$

10  
4 **EXE**



Combinations:

$$\text{[Probability]} > [\text{Combination}(C)]$$

10  
4 **EXE**



## Random Number

This function generates a pseudo random number in the range of 0.000 to 0.999. The result is displayed as a fraction when MathI/MathO is selected for Input/Output on the SETTINGS menu.

### Note

- Ran# cannot be input with Solver of the Equation app.

**Example:** To obtain random three-digit integers

$$\text{[Probability]} > [\text{Random Number}]$$

1000  
**EXE**

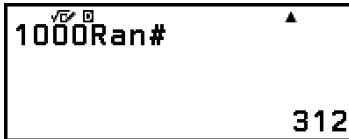

(The result differs with each execution.)

## Random Integer

This function generates a pseudo random integer between a specified start value and end value.

### Note

- RanInt# cannot be input with Solver of the Equation app.

**Example:** To generate random integers in the range of 1 to 6

$$\text{[Probability]} > [\text{Random Integer}]$$

1 **↑** **↓** (,) 6 **↓**  
**EXE**

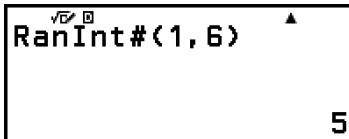

(The result differs with each execution.)

# Numeric Calculations

This section explains commands and functions that you can input after performing the operation:  $\text{[MATH]} - [\text{Numeric Calc}]$ .

## GCD, LCM

GCD determines the greatest common divisor of two values, while LCM determines the least common multiple.

**Example 1:** To determine the greatest common divisor of 28 and 35

$$\text{[MATH]} - [\text{Numeric Calc}] > [\text{GCD}]$$

28  $\text{[↑]}$   $\text{[)]}$   $\text{[,]}$  35  $\text{[)]}$   $\text{[EXE]}$

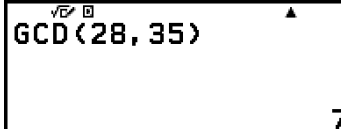

The calculator screen displays the function GCD(28, 35) and the result 7. The screen also shows the  $\sqrt{\square}$  icon in the top left and a triangle icon in the top right.

**Example 2:** To determine the least common multiple of 9 and 15

$$\text{[MATH]} - [\text{Numeric Calc}] > [\text{LCM}]$$

9  $\text{[↑]}$   $\text{[)]}$   $\text{[,]}$  15  $\text{[)]}$   $\text{[EXE]}$

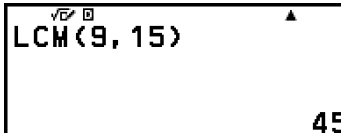

The calculator screen displays the function LCM(9, 15) and the result 45. The screen also shows the  $\sqrt{\square}$  icon in the top left and a triangle icon in the top right.

## Absolute Value

When you are performing a real number calculation, this function simply obtains the absolute value.

**Example:**  $|2 - 7| = \text{Abs}(2 - 7) = 5$   
(Input/Output: MathI/MathO)

$$\text{[MATH]} - [\text{Numeric Calc}] > [\text{Absolute Value}]$$

2  $\text{[-]}$  7  $\text{[EXE]}$



The calculator screen displays the function |2-7| and the result 5. The screen also shows the  $\sqrt{\square}$  icon in the top left and a triangle icon in the top right.

(Input/Output: LineI/LineO)

$$\text{[MATH]} - [\text{Numeric Calc}] > [\text{Absolute Value}]$$

2  $\text{[-]}$  7  $\text{[)]}$   $\text{[EXE]}$

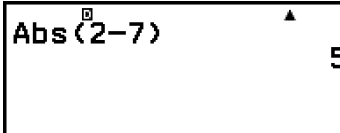

The calculator screen displays the function Abs(2-7) and the result 5. The screen also shows the  $\sqrt{\square}$  icon in the top left and a triangle icon in the top right.

## Recurring Decimal

You can use the menu item below to input a recurring decimal.

$\text{[MATH]} - [\text{Numeric Calc}] > [\text{Recurring Decimal}]$

For details, see "[Recurring Decimal Conversion \(Recurring Decimal Calculations\)](#)" (page 51).

## Round Off

Using the Round Off function (Rnd) causes decimal fraction values of the argument to be rounded in accordance with the current Number Format setting. For example, the internal and displayed result of  $\text{Rnd}(10 \div 3)$  is 3.333 when the Number Format setting is "Fix3:0.123". Using the Norm1:  $1.23 \times 10^{-3}$  or Norm2: 0.00123 setting cause the argument to be rounded off at the 11th digit of the mantissa part.

**Example:** To perform the following calculations when "Fix3:0.123" is selected for the number of display digits:  $10 \div 3 \times 3$  and  $\text{Rnd}(10 \div 3) \times 3$

(Input/Output: MathI/DecimalO, Number Format: Fix3:0.123)

$10 \div 3 \times 3 \text{ EXE}$

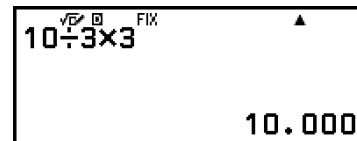

$\text{Rnd}(10 \div 3) \times 3 \text{ EXE}$



## Angle Unit, Polar/Rectangular Coordinate, Sexagesimal

This section explains commands, functions, and symbols that you can input after performing the operation:  $\text{Angle/Coord/Sexa}$ .

### Degrees, Radians, Gradians

These functions specify the angle unit.

$^\circ$  specifies degree,  $^r$  radian, and  $^g$  gradian.

You can input each function using the menu items below.

$\text{Angle/Coord/Sexa}$  > [Degrees]

$\text{Angle/Coord/Sexa}$  > [Radians]

$\text{Angle/Coord/Sexa}$  > [Gradians]

**Example:**  $\pi/2$  radians =  $90^\circ$  (Angle Unit: Degree)

$\text{Angle/Coord/Sexa}$  > [Radians]



## Rect to Polar, Polar to Rect

"Pol(" converts rectangular coordinates to polar coordinates, while "Rec(" converts polar coordinates to rectangular coordinates.

$$\text{Pol}(x, y) = (r, \theta) \quad \text{Rec}(r, \theta) = (x, y)$$

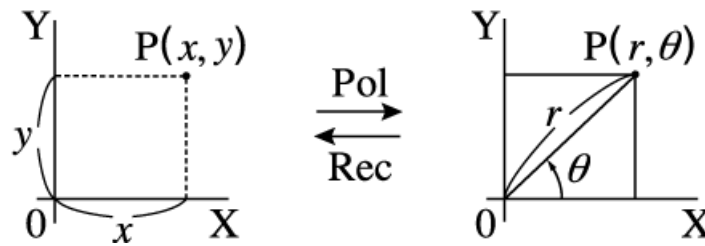

- Specify the Angle Unit on the SETTINGS menu before performing calculations.
- The calculation result for  $r$  and  $\theta$  and for  $x$  and  $y$  are each stored respectively to variables  $x$  and  $y$ .
- Calculation result  $\theta$  is displayed in the range of  $-180^\circ < \theta \leq 180^\circ$ .

### Note

- Pol( and Rec( can be used on the calculation screen of the calculator apps below. Calculate, Statistics, Matrix, Vector

**Example 1:** To convert rectangular coordinates  $(\sqrt{2}, \sqrt{2})$  to polar coordinates (Input/Output: MathI/MathO, Angle Unit: Degree)

☰ – [Angle/Coord/Sexa] > [Rect to Polar]  
 $\sqrt{2}$  >  $\sqrt{2}$  > (,)  $\sqrt{2}$  > ) EXE

**Example 2:** To convert polar coordinates  $(\sqrt{2}, 45^\circ)$  to rectangular coordinates (Input/Output: MathI/MathO, Angle Unit: Degree)

☰ – [Angle/Coord/Sexa] > [Polar to Rect]  
 $\sqrt{2}$  >  $\uparrow$  > (,) 45 > ) EXE

## Degrees, Minutes, Seconds

You can use the keys or the menu item below to input the sexagesimal symbol ( $^\circ$ ).

$\uparrow$  + (°'")

☰ – [Angle/Coord/Sexa] > [Degr Mins Secs]

For details, see "**Sexagesimal Conversion (Degree, Minute, Second Calculations)**" (page 54).

# Hyperbolic, Trigonometric

This section explains hyperbolic and trigonometric functions.

## Hyperbolic Functions

Hyperbolic functions can be input using the menu items below.

$\text{[2nd]} - [\text{Hyperbolic/Trig}] > [\text{sinh}], [\text{cosh}], [\text{tanh}], [\text{sinh}^{-1}], [\text{cosh}^{-1}], \text{ or } [\text{tanh}^{-1}]$

The angle unit setting does not affect calculations.

**Example:**  $\sinh 1 = 1.175201194$

$\text{[2nd]} - [\text{Hyperbolic/Trig}] > [\text{sinh}] 1 \text{[)] [EXE]}$

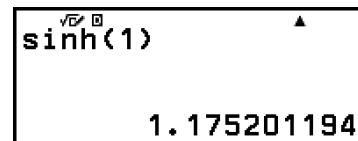

## Trigonometric Functions

Trigonometric functions can be input using the keys or menu items below.

Key	Menu Item
$\text{[sin]}$	$\text{[2nd]} - [\text{Hyperbolic/Trig}] > [\text{sin}]$
$\text{[cos]}$	$\text{[2nd]} - [\text{Hyperbolic/Trig}] > [\text{cos}]$
$\text{[tan]}$	$\text{[2nd]} - [\text{Hyperbolic/Trig}] > [\text{tan}]$
$\text{[2nd]} \text{[sin]} (\text{sin}^{-1})$	$\text{[2nd]} - [\text{Hyperbolic/Trig}] > [\text{sin}^{-1}]$
$\text{[2nd]} \text{[cos]} (\text{cos}^{-1})$	$\text{[2nd]} - [\text{Hyperbolic/Trig}] > [\text{cos}^{-1}]$
$\text{[2nd]} \text{[tan]} (\text{tan}^{-1})$	$\text{[2nd]} - [\text{Hyperbolic/Trig}] > [\text{tan}^{-1}]$

Specify the Angle Unit on the SETTINGS menu before performing calculations.

**Example:**  $\sin 30 = \frac{1}{2}$  (Angle Unit: Degree)

$\text{[sin]} 30 \text{[)] [EXE]}$

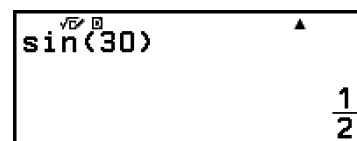

# Scientific Constants

Your calculator comes with 47 built-in scientific constants. The values are based on CODATA (2022) recommended values.

**Example:** To input the scientific constant  $c$  (speed of light in vacuum), and display its value

1. Press  $\text{[Sci]}$ , select [Sci Constants], and then press  $\text{[OK]}$ .

- This displays a menu of scientific constant categories\*.

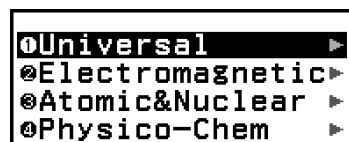

2. Select [Universal], and then press  $\text{[OK]}$ .

- This displays a menu of scientific constants in the Universal category.

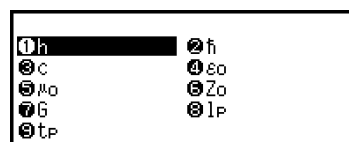

3. Select [ $c$ ], and then press  $\text{[OK]}$ .

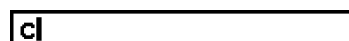

4. Press  $\text{[EXE]}$ .

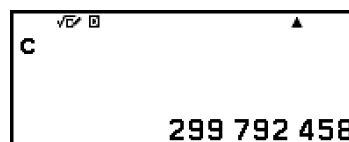

\* The table below shows the scientific constants included in each category.

Category	Scientific Constants
Universal	$h, \hbar, c, \epsilon_0, \mu_0, Z_0, G, I_P, t_P$
Electromagnetic	$\mu_N, \mu_B, e, \Phi_0, G_0, K_J, R_K$
Atomic&Nuclear	$m_p, m_n, m_e, m_\mu, a_0, \alpha, r_e, \lambda_C, \gamma_p, \lambda_{Cp}, \lambda_{Cn}, R_\infty, \mu_p, \mu_e, \mu_n, \mu_\mu, m_\tau$
Physico-Chem	$m_u, F, N_A, k, V_m, R, c_1, c_2, \sigma$
Adopted Values	$g_n, \text{atm}, R_{K-90}, K_{J-90}$

Other	t
-------	---

# Unit Conversions

You can use the unit conversion commands to convert from one unit of measurement to another. Conversion formula data is based on the "NIST Special Publication 811 (2008)".

**Example:** To convert 5 cm into inches (Input/Output: LineI/LineO)

1. Input the value to be converted.

5

2. Press  $\text{F2}$ , select [Unit Conversions], and then press  $\text{OK}$ .

- This displays a menu of unit conversion categories\*.



3. Select [Length], and then press  $\text{OK}$ .

- This displays a menu of conversion commands in the Length category.

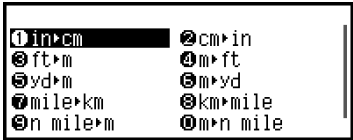

4. Select [cm to in] (the centimeters-to-inches conversion command) and then press  $\text{OK}$ .

5. Press  $\text{EXE}$ .

\* The table below shows the unit conversion commands included in each category.

Category	Unit Conversion Commands
Length	in to cm, cm to in, ft to m, m to ft, yd to m, m to yd, mile to km, km to mile, n mile to m, m to n mile, pc to km, km to pc

Area	acre ► m <sup>2</sup> , m <sup>2</sup> ► acre
Volume	gal(US) ► L, L ► gal(US), gal(UK) ► L, L ► gal(UK)
Mass	oz ► g, g ► oz, lb ► kg, kg ► lb
Velocity	km/h ► m/s, m/s ► km/h
Pressure	atm ► Pa, Pa ► atm, mmHg ► Pa, Pa ► mmHg, kgf/cm <sup>2</sup> ► Pa, Pa ► kgf/cm <sup>2</sup> , lbf/in <sup>2</sup> ► kPa, kPa ► lbf/in <sup>2</sup>
Energy	kgf • m ► J, J ► kgf • m, J ► cal <sub>15</sub> , cal <sub>15</sub> ► J
Power	hp ► kW, kW ► hp
Temperature	°F ► °C, °C ► °F

## Others

Functions and symbols that can be input with the calculator keys can also be input using the [Other] menu. Use  $\text{Ⓜ}$  – [Other] to display the function and symbol menu. For example, to input Ans, you could either press  $\text{Ⓜ}$  or perform the following operation:  $\text{Ⓜ}$  – [Other] > [Ans].

The table below shows the [Other] menu item that corresponds to each key operation.

Menu Item	Key
Ans	$\text{Ⓜ}$
$\pi$	$\text{⬆} \text{7} (\pi)$
$e$	$\text{⬆} \text{8} (e)$
$\sqrt{\quad}$	$\text{Ⓜ}$
$^x\sqrt{\quad}$	$\text{⬆} \text{Ⓜ} (\sqrt[x]{\quad})$
-1 *1	$\text{⬆} \text{Ⓜ} (\text{■}^{-1})$
2 *2	$\text{Ⓜ}^2$

^ (	⊠ <sup>2</sup>
- *3	⬆ ⊖ ((-))
,	⬆ ⊃ ) (,)
(	⊂
)	⊃

\*1 Reciprocal

\*2 Square

\*3 Minus sign

# Registering and Using Defining Equations for $f(x)$ and $g(x)$

## Registering and Using Defining Equations for $f(x)$ and $g(x)$

Your calculator includes "f(" and "g(" functions that you can use after registering defining equations for them. For example, after registering  $f(x) = x^2 + 1$  as a defining equation for the "f(" function, you can calculate  $f(0) = 1$  and  $f(5) = 26$ .

Pressing  $\text{f}(x)$  displays a menu for registering the defining equation of  $f(x)$  or  $g(x)$ , and for inputting "f(" or "g(".

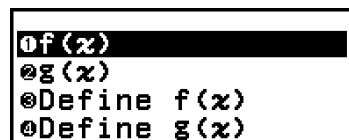

### Note

- The defining equations of  $f(x)$  and  $g(x)$  are also used by  $f(x)$  and  $g(x)$  in the Table app. For information about the Table app, see "[Creating a Number Table](#)" (page 93).

## Registering a Defining Equation

**Example 1:** To register  $f(x) = x^2 + 1$

1. Press  $\text{CALC}$ , select the Calculate app icon, and then press  $\text{OK}$ .
2. Press  $\text{f}(x)$ , and then select [Define  $f(x)$ ].
  - This displays the  $f(x)$  equation registration screen.

A screenshot of a calculator screen with a white background and black text. The text reads "f(x)=" followed by a cursor.

3. Input  $x^2 + 1$ .

A screenshot of a calculator screen with a white background and black text. The text reads "f(x)=x^2+1" followed by a cursor. Above the text are three small circular icons containing the symbols x, x^2, and +.

4. Press  $\text{EXE}$ .
  - This registers the expression you input, and the screen that was shown before you pressed  $\text{f}(x)$  in step 2 of this procedure re-appears.

### Note

- A defining equation can be registered from any calculator app except Equation (Simul Equation / Polynomial), Inequality, Distribution, Ratio, Math Box and Base-N. However,

depending on the screen displayed by the calculator app (for example, if a menu screen is displayed), the menu may not appear when you press  $\text{f(x)}$ .

## Performing a Calculation by Assigning a Value to the Registered Defining Equation

**Example 2:** To assign the value  $x = 3$  to  $f(x)$ , which you registered in

Example 1

(Continuing from Example 1)

1. Press  $\text{f(x)}$ , and then select  $[f(x)]$ .

- This inputs "f".

f (|

2. Assign a value of 3 and then execute the calculation.

3 ( ) (EXE)  $\text{f}(3)$  10

## Registering a Composite Function

**Example 3:** To insert  $f(x)$  defined in Example 1 into  $g(x)$  in order to register

$$g(x) = f(x) \times 2 - x$$

(Continuing from Example 1)

1. Press  $\text{f(x)}$ , and then select  $[Define\ g(x)]$ .

- This displays the  $g(x)$  equation registration screen.

g (x) =

2. Input  $f(x) \times 2 - x$ .

$\text{f(x)}$  \* (EXE) (x) ( ) (x) 2 ( - ) (x)  $\text{g}(x) = f(x) \times 2 - x$

- \* Pressing  $\text{f(x)}$  while the  $g(x)$  equation registration screen is displayed, the only menu item that appears is  $[f(x)]$ . In the same way, pressing  $\text{f(x)}$  while the  $f(x)$  equation registration screen is displayed, the only menu item that appears is  $[g(x)]$ .

3. Press (EXE).

- This registers the equation you input and returns to the screen displayed before you started this operation with step 1.

### Note

- The operation for assigning a value to  $x$  of  $g(x)$  and calculating the result is the same as that under "Performing a Calculation by Assigning a Value to the Registered Defining Equation" (page 72). However, note that instead of selecting  $[f(x)]$  in step 1, you should select  $[g(x)]$ .

- In the operation of Example 3, you input  $f(x)$  into the defining equation of  $g(x)$ . Conversely, you can also input  $g(x)$  into the  $f(x)$  defining equation. However, do not have  $g(x)$  input into  $f(x)$ , and  $f(x)$  input into  $g(x)$  at the same time. If you do, a Circular ERROR will occur when you perform a calculation using  $f(x)$  or  $g(x)$ .

## Data Retention

Performing any one of the operations below causes the defining equations registered to  $f(x)$  and  $g(x)$  to be deleted.

- Pressing  $\text{⏏}$
- Using the SETTINGS menu to switch the Input/Output setting between MathI\*<sup>1</sup> and LineI\*<sup>2</sup>.
  - \*1 MathI/MathO or MathI/DecimalO
  - \*2 LineI/LineO or LineI/DecimalO
- Executing  $\text{⊞} - [\text{Reset}] > [\text{Settings \& Data}]$  or  $\text{⊞} - [\text{Reset}] > [\text{Initialize All}]$

# Using QR Code Functions

## Using QR Code Functions

Your calculator can display QR Code symbols that can be read by a smart device.

### Important!

- The operations in this section assume that the smart device being used has a QR Code reader that can read multiple QR Code symbols, and it can connect to the Internet.
- Scanning a QR Code displayed by this calculator with a smart device will cause the smart device to access the CASIO website.

### Note

- QR Code appears on the display whenever you press  $\uparrow$  (X) (QR) while any one of the screens below is displayed.
    - HOME screen
    - SETTINGS menu screen
    - Error screens
    - Calculation result screens in any calculator app
    - Table screens in any calculator app
    - Spreadsheet app screen
- For details, visit the CASIO website (<https://wes.casio.com>).

## Displaying a QR Code

**Example:** To display the QR Code for a calculation result in the calculator's Calculate app and scan it with a smart device

1. In the Calculate app, perform some calculation.
2. Press  $\uparrow$  (X) (QR) to display the QR Code.
  - The numbers in the lower right corner of the display show the current QR Code number and the total number of QR Code symbols. To display the next QR Code, press  $\downarrow$  or  $\text{OK}$ .

### Note

- To return to a previous QR Code, press  $\downarrow$  or  $\text{OK}$  as many times as required to scroll forward until it appears.

3. Use a smart device to scan the QR Code on the calculator display.
  - For information about how to scan a QR Code, refer to the user documentation of the QR Code reader you are using.

## **| If You Experience Difficulty Scanning a QR Code**

While the QR Code is displayed, use ⏪ and ⏩ to adjust the display contrast of the QR Code. This contrast adjustment affects QR Code displays only.

### **Important!**

- Depending on the smart device and/or QR Code reader app being used, you may experience problems scanning the QR Code symbols produced by this calculator.
- When the "QR Code" setting on the SETTINGS menu is "Version 3", the calculator apps that can display QR Code symbols are limited. If you try to display a QR Code in an app that does not support QR Code display, the message "Not Supported (Version 3)" will appear. However, the QR Code produced by this setting is easier to scan with a smart device.
- For more information, visit the CASIO website (<https://wes.casio.com>).

# Using Calculator Apps

## Statistical Calculations

The Statistics app calculates various statistical values based on single-variable ( $x$ ) or paired-variable ( $x, y$ ) data.

### General Procedure for Performing a Statistical Calculation

1. Press  $\text{2ND}$ , select the Statistics app icon, and then press  $\text{OK}$ .
2. On the menu that appears, select [1-Variable] (single-variable) or [2-Variable] (paired-variable), and then press  $\text{OK}$ .
  - This displays the Statistics Editor.

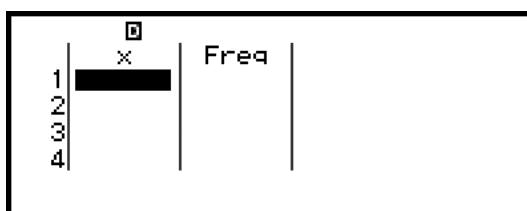

Single-variable

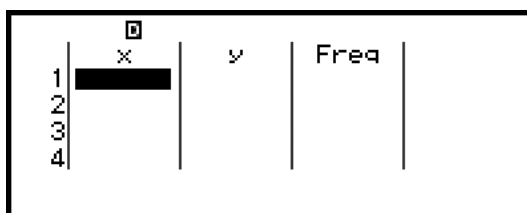

Paired-variable

- You can use the Freq column to specify the frequency of each sample value. For details, see "[Freq \(Frequency\) Column](#)" (page 77).
3. Input data.
    - For details, see "[Inputting Data with Statistics Editor](#)" (page 77).
  4. After you finish inputting data, press  $\text{OK}$ .
    - This causes the menu below to appear.



Single-variable

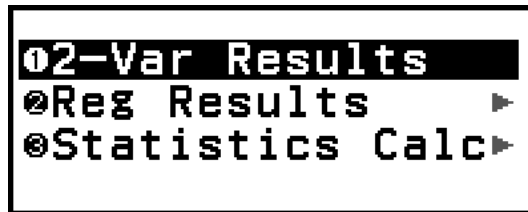

Paired-variable

5. Select the menu item for the operation you want to perform.
  - Select [1-Var Results], [2-Var Results], or [Reg Results] to see a list of calculation results based on the data you entered. For details, see ["Displaying Statistical Calculation Results" \(page 80\)](#).
  - To display a statistical calculation screen for performing calculations based on the input data, select [Statistics Calc]. For details, see ["Using Statistical Calculation Screen" \(page 84\)](#).

#### Note

- To return to the Statistics Editor from a statistical calculation screen, press  $\text{AC}$  and then  $\text{↩}$ .

## Inputting Data with Statistics Editor

Statistics Editor displays one, two, or three columns: single-variable ( $x$ ), single-variable and frequency ( $x$ , Freq), paired-variable ( $x$ ,  $y$ ), paired-variable and frequency ( $x$ ,  $y$ , Freq). The number of data rows that can be input depends on the number of columns: 160 rows for one column, 80 rows for two columns, 53 rows for three columns.

#### Important!

- All data currently input in the Statistics Editor is deleted whenever you perform any of the operations below.
  - Switching the statistical calculation type between single-variable and paired-variable
  - Changing the Frequency setting on the TOOLS menu
- Statistical calculations can take considerable time when there are a large number of data items.

## Freq (Frequency) Column

If you turn on the Frequency setting on the TOOLS menu, a column labeled "Freq" will also be included on the Statistics Editor. You can use the Freq column to specify the frequency (the number of times the same sample appears in the data group) of each sample value.

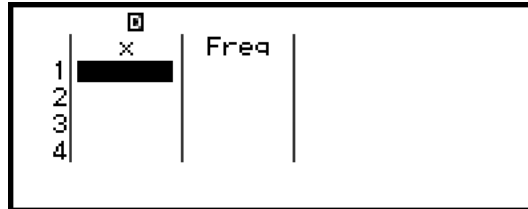

Single-variable

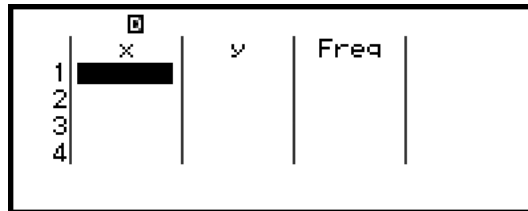

Paired-variable

### To hide the Freq column

1. While the Statistics Editor is displayed, press  $\odot$  and then select [Frequency] > [Off].
2. Press  $\text{AC}$  to return to the Statistics Editor.

### To display the Freq column

1. While the Statistics Editor is displayed, press  $\odot$  and then select [Frequency] > [On].
2. Press  $\text{AC}$  to return to the Statistics Editor.

## Rules for Inputting Sample Data on the Statistics Editor

Data you input is inserted into the cell where the cursor is located. Use the cursor keys to move the cursor between cells.

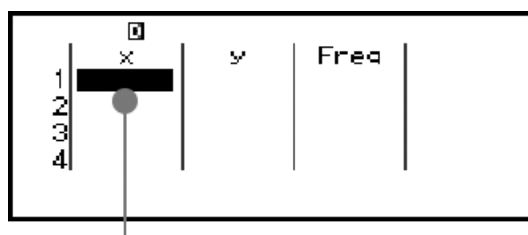

Cursor

After inputting a value, press  $\text{EXE}$ . This registers the value and displays up to six of its digits in the cell.

**Example 1:** To select paired-variable and input the following data: (170, 66), (179, 75), (173, 68)

1. Press  $\text{STAT}$ , select the Statistics app icon, and then press  $\text{OK}$ .
2. Select [2-Variable], and then press  $\text{OK}$ .

	x	y	Freq
1			
2			
3			
4			

3. Use the operation below to input data.

170 $\text{\textcircled{EXE}}$  179 $\text{\textcircled{EXE}}$  173 $\text{\textcircled{EXE}}$   $\text{\textcircled{V}}$   $\text{\textcircled{>}}$   
 66 $\text{\textcircled{EXE}}$  75 $\text{\textcircled{EXE}}$  68 $\text{\textcircled{EXE}}$

	x	y	Freq
1	170	66	1
2	179	75	1
3	173	68	1
4			

### Note

- On the Statistics Editor, you can store the value in a cell to a variable. For example, performing the following operation while the screen in step 3 is displayed above will store 68 to variable A:  $\text{\textcircled{^}} \text{\textcircled{2}} \text{\textcircled{3}} - [A=] > [\text{Store}]$ . For details about variables, see "**Variables (A, B, C, D, E, F, x, y, z)**" (page 43).

## Editing Sample Data

### To replace the data in a cell

On the Statistics Editor, move the cursor to the cell containing the data you want to edit, input the new data, and then press  $\text{\textcircled{EXE}}$ .

### To delete a row

On the Statistics Editor, move the cursor to the row you want to delete and then press  $\text{\textcircled{X}}$ .

### To insert a row

- On the Statistics Editor, move the cursor to the row that will be under the row you will insert.
- Perform the following operation:  $\text{\textcircled{000}} - [\text{Edit}] > [\text{Insert Row}]$ .

### To delete all Statistics Editor contents

On the Statistics Editor, perform the following operation:  $\text{\textcircled{000}} - [\text{Edit}] > [\text{Delete All}]$ .

## Sorting Data

You can sort Statistics Editor data in ascending or descending order on its  $x$ ,  $y$ , or Freq-column values.

### Important!

- Note that after you change the data sort sequence, you will not be able to return it to its original sequence.

**Example 2:** To sort the data input in **Example 1 (page 78)** in ascending order on the  $x$  column, and then in descending order on the  $y$  column

1. Use the procedure in Example 1 to input the data.

	x	y	Freq
1	170	66	1
2	179	75	1
3	173	68	1
4			

2. Sort the data in ascending order on the  $x$  column.

$\odot$  – [Sort] > [x Ascending]

	x	y	Freq
1	170	66	1
2	173	68	1
3	179	75	1
4			

**170**

3. Sort the data in descending order on the  $y$  column.

$\odot$  – [Sort] > [y Descending]

	x	y	Freq
1	179	75	1
2	173	68	1
3	170	66	1
4			

**75**

## Displaying Statistical Calculation Results

### Displaying Single-Variable Statistical Calculation Results

The 1-Var Results screen shows a list of various statistical values (such as mean and population standard deviation) calculated based on single-variable data. This section describes the operation required to display the 1-Var Results screen.

**Example 3:** To input the data below and display single-variable statistical calculation results

$x$	1	2	3	4	5	6	7	8	9	10
Freq	1	2	1	2	2	2	3	4	2	1

- Press  $\odot$ , select the Statistics app icon, and then press  $\text{OK}$ .
- Select [1-Variable], and then press  $\text{OK}$ .
  - This displays the Statistics Editor.
- Input data into the  $x$ -column.

1  $\text{EXE}$  2  $\text{EXE}$  3  $\text{EXE}$  4  $\text{EXE}$  5  $\text{EXE}$  6  $\text{EXE}$  7  $\text{EXE}$  8  $\text{EXE}$  9  $\text{EXE}$  10  $\text{EXE}$

	x	Freq
8	9	1
9	10	1
10		
11		

4. Input data into the Freq column.

$\nabla$   $\triangleright$   $\nabla$  2  $\text{EXE}$   $\nabla$  2  $\text{EXE}$  2  $\text{EXE}$  2  $\text{EXE}$  3  $\text{EXE}$  4  $\text{EXE}$  2  $\text{EXE}$

	$\square$		
7	x	7	Freq
8			3
9		8	4
10		9	2
		10	1

5. Press  $\text{OK}$ .

<b>1-Var Results</b>
$\text{Statistics Calc}$

6. Select [1-Var Results], and then press  $\text{OK}$ .

- This displays the 1-Var Results screen.

$\square$	
$\bar{x}$	=5.95
$\Sigma x$	=119
$\Sigma x^2$	=837
$\sigma^2 x$	=6.4475
$\sigma x$	=2.539192785
$s^2 x$	=6.786842105

$\nabla$  (or  $\nabla$ )

$\square$	
$s_x$	=2.605156829
n	=20
min(x)	=1
Q1	=4
Med	=6.5
Qs	=8

$\nabla$  (or  $\nabla$ )

$\square$	
max(x)	=10

- For the meanings of the variables shown on the 1-Var Results screen, see the **"List of Statistical Value Variables and Statistical Calculation Functions"** (page 87).

7. Press  $\text{2nd}$  or  $\text{AC}$  to return to the Statistics Editor.

## Displaying Paired-Variable Statistical Calculation Results

The 2-Var Results screen shows a list of various statistical values (such as mean and population standard deviation) calculated based on paired-variable data. This section describes the operation required to display the 2-Var Results screen.

**Example 4:** To input the data below and display paired-variable statistical calculation results

$x$	1.0	1.2	1.5	1.6	1.9	2.1	2.4	2.5	2.7	3.0
$y$	1.0	1.1	1.2	1.3	1.4	1.5	1.6	1.7	1.8	2.0

- Press  $\text{2nd}$ , select the Statistics app icon, and then press  $\text{OK}$ .
- Select [2-Variable], and then press  $\text{OK}$ .
  - This displays the Statistics Editor.
- Press  $\text{2nd}$  and then select [Frequency] > [Off].

- Press  $\text{AC}$  to return to the Statistics Editor.

4. Input data into the  $x$ -column.

1  $\text{EXE}$  1  $\text{.}$  2  $\text{EXE}$  1  $\text{.}$  5  $\text{EXE}$  1  $\text{.}$  6  $\text{EXE}$  1  $\text{.}$  9  $\text{EXE}$   
 2  $\text{.}$  1  $\text{EXE}$  2  $\text{.}$  4  $\text{EXE}$  2  $\text{.}$  5  $\text{EXE}$  2  $\text{.}$  7  $\text{EXE}$  3  $\text{EXE}$

	x	y
8	2.5	0
9	2.7	0
10	3	0
11		

5. Input data into the  $y$ -column.

$\text{V}$   $\text{>}$  1  $\text{EXE}$  1  $\text{.}$  1  $\text{EXE}$  1  $\text{.}$  2  $\text{EXE}$  1  $\text{.}$  3  $\text{EXE}$  1  $\text{.}$  4  $\text{EXE}$   
 1  $\text{.}$  5  $\text{EXE}$  1  $\text{.}$  6  $\text{EXE}$  1  $\text{.}$  7  $\text{EXE}$  1  $\text{.}$  8  $\text{EXE}$  2  $\text{EXE}$

	x	y
8	2.5	1.7
9	2.7	1.8
10	3	2
11		

6. Press  $\text{OK}$ .

<b>2-Var Results</b>
<b>Reg Results</b> $\blacktriangleright$
<b>Statistics Calc</b> $\blacktriangleright$

7. Select [2-Var Results], and then press  $\text{OK}$ .

- This displays the 2-Var Results screen.

	Value
$\Sigma x$	=1.99
$\Sigma y$	=19.9
$\Sigma x^2$	=43.57
$\Sigma xy$	=0.3969
$\sigma_x$	=0.63
$s^2_x$	=0.441

$\text{V}$  (or  $\text{V}$ )

	Value
$s_x$	=0.6640783086
$n$	=10
$\bar{y}$	=1.46
$\Sigma y$	=14.6
$\Sigma y^2$	=22.24
$\sigma_y$	=0.0924

$\text{V}$  (or  $\text{V}$ )

	Value
$\sigma_y$	=0.3039736831
$s^2_y$	=0.1026666667
$s_y$	=0.3204163958
$\Sigma xy$	=30.96
$\Sigma x^3$	=102.451
$\Sigma x^2y$	=71.244

$\text{V}$  (or  $\text{V}$ )

	Value
$\Sigma x^4$	=253.5541
$\text{min}(x)$	=1
$\text{max}(x)$	=3
$\text{min}(y)$	=1
$\text{max}(y)$	=2

- For the meanings of the variables shown on the 2-Var Results screen, see the "[List of Statistical Value Variables and Statistical Calculation Functions](#)" (page 87).

8. Press  $\text{S}$  or  $\text{AC}$  to return to the Statistics Editor.

## Displaying Regression Calculation Results

The Reg Results screen displays a list of regression calculation results (coefficients of regression equations) based on paired-variable data. This

section describes the operation required to display the Reg Results screen.

**Example 5:** To use the paired-variable data input in [Example 4 \(page 81\)](#) and display the results of the two regression calculations shown below

- The regression equation " $y = a + bx$ " coefficients ( $a$ ,  $b$ ), and the correlation coefficient ( $r$ ) when linear regression is performed on the data
- The regression equation " $y = a + bx + cx^2$ " coefficients ( $a$ ,  $b$ ,  $c$ ) when quadratic regression is performed on the data

#### Note

- For information about regression calculation types supported by the Statistics app, see the ["Supported Regression Type List" \(page 84\)](#).

1. Perform steps 1 through 6 of the procedure under [Example 4 \(page 81\)](#).
2. Select [Reg Results], and then press **OK**.
  - This displays the regression type menu.

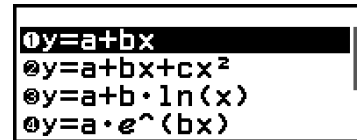

3. Select [ $y=a+bx$ ], and then press **OK**.
  - This displays the linear regression Reg Results screen.

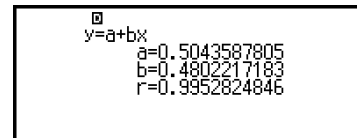

4. Press **↵** or **AC** to return to the Statistics Editor.
5. Press **OK**, and then select [Reg Results] > [ $y=a+bx+cx^2$ ].
  - This displays quadratic regression Reg Results screen.

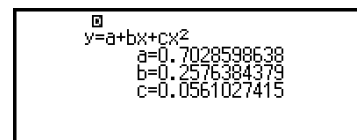

6. Press **↵** or **AC** to return to the Statistics Editor.
  - For the meanings of the variables shown on the Reg Results screen, see the ["List of Statistical Value Variables and Statistical Calculation Functions" \(page 87\)](#).

## Supported Regression Type List

Regression Type	Regression Equation (regression type menu item)
Linear Regression	$y = a + bx$
Quadratic Regression	$y = a + bx + cx^2$
Logarithmic Regression	$y = a + b \cdot \ln(x)$
$e$ exponential Regression	$y = a \cdot e^{(bx)}$
$ab$ exponential Regression	$y = a \cdot b^x$
Power Regression	$y = a \cdot x^b$
Inverse Regression	$y = a + b/x$

## Using Statistical Calculation Screen

You can use the statistical calculation screen to recall individual statistical values and use the values in calculations.



Screen without calculation expression input

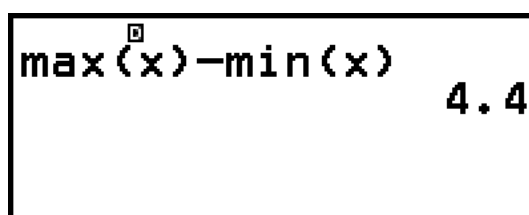

Example calculation

To recall a statistical value, use a variable representing the statistical value you want to recall (for example,  $\bar{x}$ ,  $x$  population standard deviation:  $\sigma_x$ ,  $x$  maximum value:  $\max(x)$ , and so on). For more information about these variables, see the ["List of Statistical Value Variables and Statistical Calculation Functions"](#) (page 87).

## Displaying a Statistical Calculation Screen

### Single-variable

1. While the Statistics Editor is displayed, press  $\text{OK}$ .
2. On the menu that appears, select [Statistics Calc] and then press  $\text{OK}$ .



### Paired-variable

1. While the Statistics Editor is displayed, press  $\text{OK}$ .
2. On the menu that appears, select [Statistics Calc] and then press  $\text{OK}$ .
  - This displays the regression type menu (see the "**Supported Regression Type List**" (page 84)).

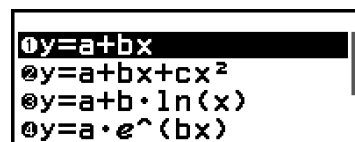

3. On the menu, select the regression type you want and then press  $\text{OK}$ .



- In the example above, use the displayed menu to select [ $y=a+bx$ ] (Linear regression).

### To return to the Statistics Editor from a statistical calculation screen

Press  $\text{AC}$ , and then  $\text{D}$ .

## Calculation Example Using the Statistical Calculation Screen

**Example 6:** To determine the sum of the sample data ( $\Sigma x$ ) and mean ( $\bar{x}$ ) of the single-variable data input in **Example 3 (page 80)**

1. Perform steps 1 through 5 of the procedure under **Example 3 (page 80)**.
2. Select [Statistics Calc], and then press  $\text{OK}$ .



3. Calculate the sum of the sample data ( $\Sigma x$ ).

$\text{2nd} - [\text{Statistics}] > [\text{Summation}] > [\Sigma x]$ 

4. Calculate the mean ( $\bar{x}$ ).

$\text{2nd} - [\text{Statistics}] > [\text{Mean/Var/Dev}\dots] > [\bar{x}]$ 

### Note

- To display the 1-Var Results screen from the statistical calculation screen above, press  $\text{2nd}$  and then select [1-Var Results]. To return to the statistical calculation screen from the 1-Var Results screen, press  $\text{left arrow}$  or  $\text{AC}$ .

**Example 7:** To determine the coefficients ( $a$ ,  $b$ ) and correlation coefficient ( $r$ ) of the linear regression equation " $y = a + bx$ " based on the paired-variable data input in **Example 4 (page 81)**

- Perform steps 1 through 6 of the procedure under **Example 4 (page 81)**.
- Select [Statistics Calc], and then press  $\text{OK}$ .
  - This displays the regression type menu.

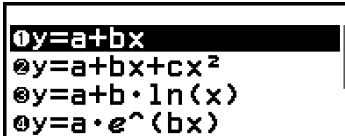

- Select [ $y=a+bx$ ], and then press  $\text{OK}$ .

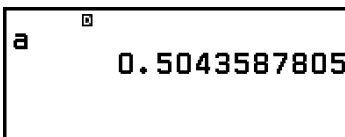

- Determine the coefficients ( $a$ ,  $b$ ) and correlation coefficient ( $r$ ) of the regression equation " $y = a + bx$ ".

$\text{2nd} - [\text{Statistics}] > [\text{Regression}] > [a]$ 

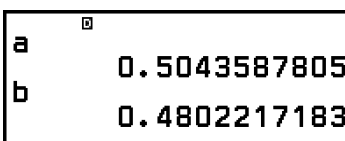
$\text{2nd} - [\text{Statistics}] > [\text{Regression}] > [b]$ 

$\square$  – [Statistics] > [Regression] > [r]

$\square$

b	0.4802217183
r	0.9952824846

- To select a different regression type, press  $\square$  and then select [Select Reg Type]. This displays the regression type menu from step 2.

### To display the 2-Var Results screen from a statistical calculation screen

Press  $\square$  and then select [2-Var Results].

### To display the Reg Results screen from a statistical calculation screen

Press  $\square$  and then select [Reg Results].

## List of Statistical Value Variables and Statistical Calculation Functions

You can use the CATALOG menu to recall variables representing statistical values and functions used for statistical calculations.

### Note

- For single-variable statistical calculations, the variables marked with an asterisk (\*) are available.
- For the calculation formula used for each variable and command, see "[Statistical Calculation Formula](#)" (page 90).

### $\square$ – [Statistics] > [Summation]

- $\Sigma x^*$ ,  $\Sigma y$  ..... sum of the sample data
- $\Sigma x^{2*}$ ,  $\Sigma y^2$  ..... sum of squares of the sample data
- $\Sigma xy$  ..... sum of products of the  $x$ -data and  $y$ -data
- $\Sigma x^3$  ..... sum of cubes of the  $x$ -data
- $\Sigma x^2y$  ..... sum of ( $x$ -data squares  $\times$   $y$ -data)
- $\Sigma x^4$  ..... sum of biquadrate of the  $x$ -data

### $\square$ – [Statistics] > [Mean/Var/Dev...]

- $\bar{x}^*$ ,  $\bar{y}$  ..... mean
- $\sigma_x^2$ ,  $\sigma_y^2$  ..... population variance
- $\sigma_x$ ,  $\sigma_y$  ..... population standard deviation
- $s_x^2$ ,  $s_y^2$  ..... sample variance
- $s_x$ ,  $s_y$  ..... sample standard deviation
- $n^*$  ..... number of items

### $\square$ – [Statistics] > [Min/Max/Quartile] (Single-Variable Data Only)

$\min(x)^*$  ..... minimum value  
 $Q_1^*$  ..... first quartile  
Med\* ..... median  
 $Q_3^*$  ..... third quartile  
 $\max(x)^*$  ..... maximum value

☞ – **[Statistics] > [Norm Dist]** (Single-Variable Data Only)  
 $P^*$ ,  $Q^*$ ,  $R^*$ ,  $\text{▶}t^*$  ..... Functions for executing normal distribution calculations. For more information about these functions, see **"Performing Normal Distribution Calculations (Single-Variable Data Only)" (page 88)**.

☞ – **[Statistics] > [Min/Max]** (Paired-Variable Data Only)  
 $\min(x)$ ,  $\min(y)$  ..... minimum value  
 $\max(x)$ ,  $\max(y)$  ..... maximum value

☞ – **[Statistics] > [Regression]** (Paired-Variable Data Only)

For quadratic regression

$a$ ,  $b$ ,  $c$  ..... regression coefficients for quadratic regression

$\hat{x}_1$ ,  $\hat{x}_2$  ..... Functions for determining  $x_1$  and  $x_2$  estimated values for an input  $y$ -value. For the argument, input the value of  $y$  immediately before the  $\hat{x}_1$  or  $\hat{x}_2$  function.

$\hat{y}$  ..... Function for determining the  $y$  estimated value for an input  $x$ -value. For the argument, input the value of  $x$  immediately before this function.

For non-quadratic regression

$a$ ,  $b$  ..... regression coefficients

$r$  ..... correlation coefficient

$\hat{x}$  ..... Function for determining  $x$  estimated value for an input  $y$ -value. For the argument, input the value of  $y$  immediately before this function.

$\hat{y}$  ..... Function for determining the  $y$  estimated value for an input  $x$ -value. For the argument, input the value of  $x$  immediately before this function.

For an example of the operation to determine estimated values, see **"Calculating Estimated Values (Paired-Variable Data Only)" (page 89)**.

## **Performing Normal Distribution Calculations (Single-Variable Data Only)**

While single-variable statistical calculation is selected, you can perform normal distribution calculation using the functions shown below from the

menu that appears when you press  $\text{2nd}$  and then select [Statistics] > [Norm Dist].

P(, Q(, R( ... These functions take the argument  $t$  and determine a probability of standard normal distribution as illustrated below.

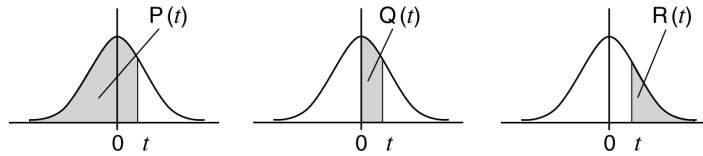

$\blacktriangleright t$  ..... This function is preceded by the argument  $x$ . It calculates the standard variate for data value  $x$  using the mean value ( $\bar{x}$ ) and population standard deviation ( $\sigma_x$ ) of data input with the Statistics Editor.

$$x \blacktriangleright t = \frac{x - \bar{x}}{\sigma_x}$$

**Example 8:** For the single-variable data input in **Example 3 (page 80)**, determine the normalized variate when  $x = 2$ , and  $P(t)$  at that point.

1. Perform steps 1 through 5 of the procedure under **Example 3 (page 80)**.
2. Select [Statistics Calc], and then press  $\text{OK}$ .



3. Calculate the normalized variate when  $x = 2$ .

$\text{2nd}$  – [Statistics] > [Norm Dist] > [ $\blacktriangleright t$ ]  $\text{EXE}$

A calculator screen showing the calculation:  $2 \blacktriangleright t = -1.555612486$ .

4. Calculate  $P(t)$ .

$\text{2nd}$  – [Statistics] > [Norm Dist] > [P(]  $\text{Ans}$   $\text{)} \text{EXE}$

A calculator screen showing the calculation:  $P(\text{Ans}) = 0.0599$ .

### Calculating Estimated Values (Paired-Variable Data Only)

Based on the regression equation obtained by paired-variable statistical calculation, the estimated value of  $y$  can be calculated for a given  $x$ -value. The corresponding  $x$ -value (two values,  $x_1$  and  $x_2$ , in the case of quadratic regression) also can be calculated for a value of  $y$  in the regression equation.

**Example 9:** To determine the estimated value for  $y$  when  $x = 5.5$  in the regression equation produced by linear regression of the data input in **Example 4 (page 81)**

1. Perform steps 1 through 6 of the procedure under **Example 4 (page 81)**.
2. Select [Statistics Calc], and then press  $\text{OK}$ .
  - This displays the regression type menu.

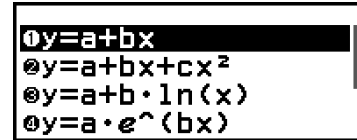

3. Select [ $y=a+bx$ ], and then press  $\text{OK}$ .



4. Input the  $x$ -value (5.5), and then input " $\hat{y}$ ", which is the function to determine the estimated value of  $y$ .

$\text{5} \text{ } \text{.} \text{ } \text{5}$   
 $\text{2ND}$  – [Statistics] > [Regression] > [ $\hat{y}$ ]



5. Press  $\text{EXE}$ .

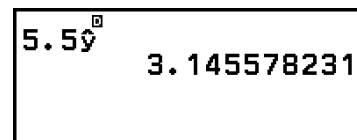

## Statistical Calculation Formula

### Single-Variable Statistical Calculation Formula

$$\bar{x} = \frac{\sum x}{n}$$

$$\sigma_x = \sqrt{\frac{\sum (x - \bar{x})^2}{n}}$$

$$s_x = \sqrt{\frac{\sum (x - \bar{x})^2}{n - 1}}$$

### Paired-Variable Statistical Calculation Formula

$$\bar{x} = \frac{\sum x}{n}$$

$$\sigma_x = \sqrt{\frac{\sum (x - \bar{x})^2}{n}}$$

$$s_x = \sqrt{\frac{\sum (x - \bar{x})^2}{n - 1}}$$

$$\bar{y} = \frac{\sum y}{n}$$

$$\sigma_y = \sqrt{\frac{\sum (y - \bar{y})^2}{n}}$$

$$s_y = \sqrt{\frac{\sum (y - \bar{y})^2}{n - 1}}$$

## Regression Calculation Formula

Linear Regression ( $y = a + bx$ )

$$a = \frac{\sum y - b \cdot \sum x}{n}$$

$$b = \frac{n \cdot \sum xy - \sum x \cdot \sum y}{n \cdot \sum x^2 - (\sum x)^2}$$

$$r = \frac{n \cdot \sum xy - \sum x \cdot \sum y}{\sqrt{\{n \cdot \sum x^2 - (\sum x)^2\} \{n \cdot \sum y^2 - (\sum y)^2\}}}$$

$$\hat{x} = \frac{y - a}{b}$$

$$\hat{y} = a + bx$$

Quadratic Regression ( $y = a + bx + cx^2$ )

$$a = \frac{\sum y}{n} - b \left( \frac{\sum x}{n} \right) - c \left( \frac{\sum x^2}{n} \right)$$

$$b = \frac{S_{xy} \cdot S_{x^2 x^2} - S_{x^2 y} \cdot S_{xx^2}}{S_{xx} \cdot S_{x^2 x^2} - (S_{xx^2})^2}$$

$$c = \frac{S_{x^2 y} \cdot S_{xx} - S_{xy} \cdot S_{xx^2}}{S_{xx} \cdot S_{x^2 x^2} - (S_{xx^2})^2}$$

$$S_{xx} = \sum x^2 - \frac{(\sum x)^2}{n}$$

$$S_{xy} = \sum xy - \frac{(\sum x \cdot \sum y)}{n}$$

$$S_{xx^2} = \sum x^3 - \frac{(\sum x \cdot \sum x^2)}{n}$$

$$S_{x^2 x^2} = \sum x^4 - \frac{(\sum x^2)^2}{n}$$

$$S_{x^2 y} = \sum x^2 y - \frac{(\sum x^2 \cdot \sum y)}{n}$$

$$\hat{x}_1 = \frac{-b + \sqrt{b^2 - 4c(a - y)}}{2c}$$

$$\hat{x}_2 = \frac{-b - \sqrt{b^2 - 4c(a - y)}}{2c}$$

$$\hat{y} = a + bx + cx^2$$

Logarithmic Regression ( $y = a + b \cdot \ln(x)$ )

$$a = \frac{\Sigma y - b \cdot \Sigma \ln x}{n}$$

$$b = \frac{n \cdot \Sigma(\ln x)y - \Sigma \ln x \cdot \Sigma y}{n \cdot \Sigma(\ln x)^2 - (\Sigma \ln x)^2}$$

$$r = \frac{n \cdot \Sigma(\ln x)y - \Sigma \ln x \cdot \Sigma y}{\sqrt{\{n \cdot \Sigma(\ln x)^2 - (\Sigma \ln x)^2\} \{n \cdot \Sigma y^2 - (\Sigma y)^2\}}}$$

$$\hat{x} = e^{\frac{y-a}{b}}$$

$$\hat{y} = a + b \ln x$$

e Exponential Regression ( $y = a \cdot e^{(bx)}$ )

$$a = \exp\left(\frac{\Sigma \ln y - b \cdot \Sigma x}{n}\right)$$

$$b = \frac{n \cdot \Sigma x \ln y - \Sigma x \cdot \Sigma \ln y}{n \cdot \Sigma x^2 - (\Sigma x)^2}$$

$$r = \frac{n \cdot \Sigma x \ln y - \Sigma x \cdot \Sigma \ln y}{\sqrt{\{n \cdot \Sigma x^2 - (\Sigma x)^2\} \{n \cdot \Sigma (\ln y)^2 - (\Sigma \ln y)^2\}}}$$

$$\hat{x} = \frac{\ln y - \ln a}{b}$$

$$\hat{y} = a e^{bx}$$

ab Exponential Regression ( $y = a \cdot b^x$ )

$$a = \exp\left(\frac{\Sigma \ln y - \ln b \cdot \Sigma x}{n}\right)$$

$$b = \exp\left(\frac{n \cdot \Sigma x \ln y - \Sigma x \cdot \Sigma \ln y}{n \cdot \Sigma x^2 - (\Sigma x)^2}\right)$$

$$r = \frac{n \cdot \Sigma x \ln y - \Sigma x \cdot \Sigma \ln y}{\sqrt{\{n \cdot \Sigma x^2 - (\Sigma x)^2\} \{n \cdot \Sigma (\ln y)^2 - (\Sigma \ln y)^2\}}}$$

$$\hat{x} = \frac{\ln y - \ln a}{\ln b}$$

$$\hat{y} = a b^x$$

Power Regression ( $y = a \cdot x^b$ )

$$a = \exp\left(\frac{\Sigma \ln y - b \cdot \Sigma \ln x}{n}\right)$$

$$b = \frac{n \cdot \Sigma \ln x \ln y - \Sigma \ln x \cdot \Sigma \ln y}{n \cdot \Sigma (\ln x)^2 - (\Sigma \ln x)^2}$$

$$r = \frac{n \cdot \Sigma \ln x \ln y - \Sigma \ln x \cdot \Sigma \ln y}{\sqrt{\{n \cdot \Sigma (\ln x)^2 - (\Sigma \ln x)^2\} \{n \cdot \Sigma (\ln y)^2 - (\Sigma \ln y)^2\}}}$$

$$\hat{x} = e^{\frac{\ln y - \ln a}{b}}$$

$$\hat{y} = a x^b$$

Inverse Regression ( $y = a + b/x$ )

$$a = \frac{\Sigma y - b \cdot \Sigma x^{-1}}{n}$$

$$b = \frac{S_{xy}}{S_{xx}}$$

$$r = \frac{S_{xy}}{\sqrt{S_{xx} \cdot S_{yy}}}$$

$$S_{xx} = \Sigma(x^{-1})^2 - \frac{(\Sigma x^{-1})^2}{n}$$

$$S_{yy} = \Sigma y^2 - \frac{(\Sigma y)^2}{n}$$

$$S_{xy} = \Sigma(x^{-1})y - \frac{\Sigma x^{-1} \cdot \Sigma y}{n}$$

$$\hat{x} = \frac{b}{y - a}$$

$$\hat{y} = a + \frac{b}{x}$$

## Creating a Number Table

You can use the Table app to create a number table based on the defining equations registered for functions  $f(x)$  and  $g(x)$ .

### General Procedure for Creating a Number Table

**Example :** To generate a number table for the function  $f(x) = x^2 + \frac{1}{2}$  for the range  $-1 \leq x \leq 1$ , incremented in steps of 0.5

1. Press  $\odot$ , select the Table app icon, and then press  $\text{OK}$ .
  - This displays the number table screen.
  - If a defining equation is not registered for either or both of  $f(x)$  and  $g(x)$  and the data at the cursor selection position is empty, a message will appear at the bottom of the screen indicating that the defining equation is not registered.

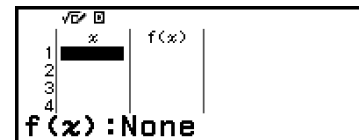

2. Configure settings to generate a number table from the function.
  - (1) Press  $\odot$ , and then select [Table Type] > [ $f(x)$ ].
  - (2) Press  $\text{AC}$ .
    - For information about settings, see "**Maximum Number of Rows in a Number Table According to Table Type**" (page 94).
3. Register a defining equation for  $f(x)$ .

$\odot\odot\odot$  – [Define  $f(x)/g(x)$ ] > [Define  $f(x)$ ]  $f(x) = x^2 + \frac{1}{2}$   
 $(x)$   $(\square^2)$   $(+)$   $(\text{2})$   $(\text{EXE})$

(Screen immediately before you pressed  $(\text{EXE})$ )

- You can also use  $(f\odot)$  to register a defining expression. For more information, see **"Defining Equation Registration" (page 95)**.

4. Configure the number table range setting.

$\odot\odot\odot$  – [Table Range]  $\uparrow$   $(-)$   $((-))$   $(1)$   $(\text{EXE})$   $(1)$   $(\text{EXE})$   $(0)$   $(.)$   $(5)$   $(\text{EXE})$   
 Table Range  
 End : 1  
 Step : 0.5  
 Execute

5. Press  $(\text{EXE})$ .

- This displays the result in the number table screen.

$x$	$f(x)$
-1	1.5
-0.5	0.75
0	0.5
0.5	0.75

- 1

- The number table generation operation causes the contents of variable  $x$  to be changed to the end value you input in step 4 above.

### Note

- On the number table screen, you can store the value in a cell to a variable. For example, performing the following operation while the screen in step 6 is displayed above will store -1 to variable A:  $(\text{2}\text{nd}\text{Fxn})$  – [A=] > [Store]. For details about variables, see **"Variables (A, B, C, D, E, F, x, y, z)" (page 43)**.

## Maximum Number of Rows in a Number Table According to Table Type

You can configure number table screen settings to show columns for both  $f(x)$  and  $g(x)$ , or for either one of them. To set it, use the menu that appears when you press  $\odot\odot\odot$  – [Table Type] while the number table screen is displayed.

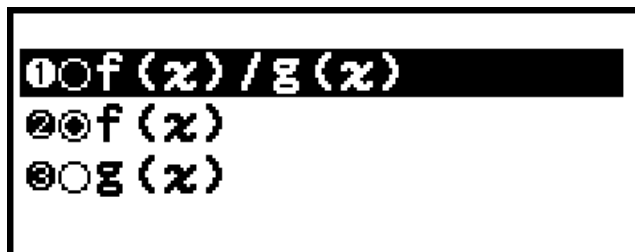

$f(x)/g(x)$  ... Show both  $f(x)$ - and  $g(x)$ -columns

$f(x)$  ... Show only  $f(x)$ -column (initial default setting)

$g(x)$  ... Show only  $g(x)$ -column

The maximum number of rows in the generated number table depends on the Table Type setting. Up to 45 rows are supported for the "f(x)" or "g(x)" setting, while 30 rows are supported for the "f(x)/g(x)" setting.

## Defining Equation Registration

There are two ways to register defining equations for  $f(x)$  and  $g(x)$ .

- While the Table app number table screen is displayed, registering an equation by pressing  $\odot\odot\odot$ 
  - $\odot\odot\odot$  – [Define f(x)/g(x)] > [Define f(x)]
  - $\odot\odot\odot$  – [Define f(x)/g(x)] > [Define g(x)]
- While the Table app number table screen is displayed, or while using any calculator app except Equation (Simul Equation / Polynomial), Inequality, Distribution, Ratio, Math Box and Base-N, registering an equation by pressing  $\textcircled{f(x)}$ 
  - $\textcircled{f(x)}$  – [Define f(x)]
  - $\textcircled{f(x)}$  – [Define g(x)]

The same  $f(x)$  or  $g(x)$  equation registration screen appears regardless of which of the two above operations is used to register defining equations.

### Note

- For details about operations using  $\textcircled{f(x)}$ , see "[Registering and Using Defining Equations for f\(x\) and g\(x\)](#)" (page 71).

## Editing Number Table Screen Data

### To delete a row

1. On the number table screen, move the cursor to the row you want to delete.
2. Press  $\textcircled{\times}$ .

### To insert a row

1. On the number table screen, move the cursor to the row that will be under the row you will insert.
2. Perform the following operation:  $\odot\odot\odot$  – [Edit] > [Insert Row].

### To delete all number table screen contents

On the number table screen, perform the following operation:  $\odot\odot\odot$  – [Edit] > [Delete All].

## To change the value input in a cell in column $x$

You can change the value in the currently highlighted  $x$  cell. Changing the  $x$  value causes the  $f(x)$  and  $g(x)$  values in the same row to be updated accordingly.

## To enter a value into the highlighted $x$ -column cell using: {value of the cell above} +/- {step value}

If there is value in the  $x$  cell above the currently highlighted  $x$  cell, pressing  $\oplus$  or  $\text{EXE}$  automatically inputs into the highlighted cell the value equal to the value of the cell above it plus the step value. So also, pressing  $\ominus$  automatically inputs the value equal to the value of the cell above less the step value. The  $f(x)$  and  $g(x)$  values in the same row are also updated accordingly.

## $f(x)$ and $g(x)$ Update Timing

$f(x)$  and  $g(x)$  values displayed on the number table screen are updated when any of the following occurs.

- When  $\text{EXE}$  is pressed while [Execute] is selected on the Table Range screen.
- When the defining equations for  $f(x)$  and  $g(x)$  are updated (except when a defining equation is a composite function).
- When a number is input into column  $x$  (including pressing  $\oplus$ ,  $\ominus$ ,  $\text{EXE}$  in column  $x$ ).

Note, however, that values are not updated automatically after the following operations.

- When the SETTINGS menu is used to change the Angle Unit setting.
- When the variable of a defining equation is updated (new numeric value stored) when a defining equation that contains a variable (example:  $f(x) = 2x + A$ ) is registered.
- When the defining equation of a composite function (Example:  $g(x) = f(x) \times 2 - x$ ) is registered, and the defining equation of the reference function (Example:  $f(x)$  of  $g(x) = f(x) \times 2 - x$ ) is updated (new defining equation registered).

In these cases, execute  $\text{ooo}$  – [Recalculate] while the number table screen is displayed to update values.

## Data Retention

Doing the following will discard some data and clear some settings of the Table app.

- ① Returning to the HOME screen and launching another calculator app.

- ② Pressing  $\downarrow$ .
- ③ Changing the Input/Output setting with the SETTINGS menu.
- ④ Changing the Table Type setting with the TOOLS menu.

The table below shows which data is discarded and which data is retained.

Operation Data, Setting	①	②	③	④
Number table data ( $x$ -, $f(x)$ -, $g(x)$ -columns)	Discarded	Discarded	Discarded	Discarded
Table Range settings	Discarded	Retained	Retained	Retained
Table Type settings	Retained	Retained	Retained	--
$f(x)$ , $g(x)$ defining equations	Retained	Discarded	Discarded	Retained

## Equation Calculations

The Equation app includes the three functions described below. After starting up the app, you can use the Equation menu that appears to select the function you want.

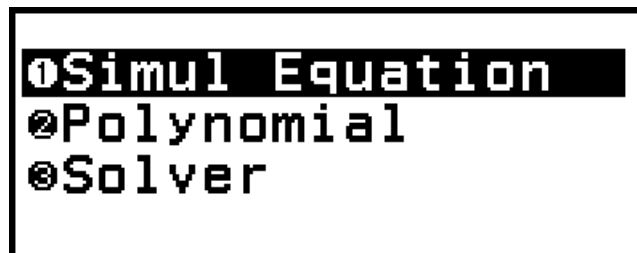

Simul Equation: Simultaneous linear equations with two to four unknowns

Polynomial: High-order equations from 2nd to 4th degree

Solver: Function to find the value of any variable contained in an input equation

### Simultaneous Linear Equations

Here, we explain the general procedure for solving a simultaneous equation with an example that solves a simultaneous linear equation with three unknowns.

**Example 1:** 
$$\begin{cases} x - y + z = 2 \\ x + y - z = 0 \\ -x + y + z = 4 \end{cases}$$

1. Press  $\odot$ , select the Equation app icon, and then press  $\text{OK}$ .
  - This displays the Equation menu.

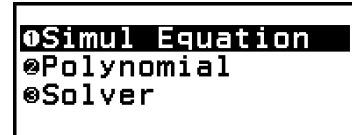

2. Select [Simul Equation], and then press  $\text{OK}$ .
  - This displays the number of unknowns menu.



3. Select [3 Unknowns], and then press  $\text{OK}$ .
  - This displays the Coefficient Editor.

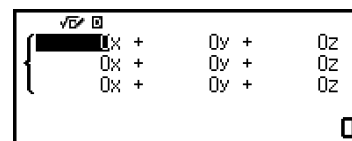

4. Use the Coefficient Editor to input coefficient values.

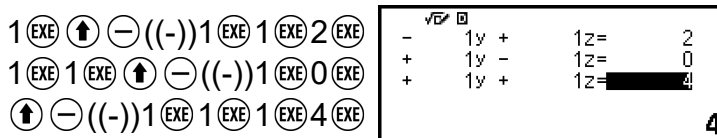

- Pressing  $\text{AC}$  while the Coefficient Editor is displayed will clear all of the coefficients to zero.
5. Press  $\text{EXE}$ .
    - This will display a solution.



- While the  $\blacktriangledown$  indicator is displayed, each press of  $\text{V}$  (or  $\text{EXE}$ ) will display another solution.

$\text{V}$  (or  $\text{EXE}$ )



$\text{V}$  (or  $\text{EXE}$ )



- Pressing  $\text{^}$  or  $\text{^}$  while the  $\blacktriangle$  indicator is displayed causes the previously displayed solution to reappear.

- Pressing  $\text{EXE}$  while the final solution is displayed returns to the Coefficient Editor. To return to the Coefficient Editor while any solution is displayed, press  $\text{AC}$ .
- Pressing  $\text{↶}$  while the Coefficient Editor is displayed returns to the number of unknowns menu.

### Note

- While the Coefficient Editor is displayed, you can store the currently highlighted value to a variable. Also, while the solution is being displayed, the currently displayed solution can be stored to a variable. For details about variables, see "**Variables (A, B, C, D, E, F, x, y, z)**" (page 43).

## High-order Equations from 2nd to 4th Degree

When you solve a high-order equation with the Equation app, the values below are displayed according to the degree of the equation.

### • Quadratic Equation

Following the display of the solution of  $ax^2+bx+c=0$ , the minimum (or maximum) coordinates  $(x, y)$  for  $y=ax^2+bx+c$  are displayed.

### • Cubic Equation

Following the display of the solution of  $ax^3+bx^2+cx+d=0$ , the coordinates  $(x, y)$  of the local minimum (or local maximum) of  $y=ax^3+bx^2+cx+d$  are displayed, only if a local minimum or local maximum exists. If a local minimum or local maximum does not exist, pressing  $\text{EXE}$  while the last solution is displayed will cause the message "No Local Max/Min" to appear.

### • Quartic Equation

The solution of  $ax^4+bx^3+cx^2+dx+e=0$  is displayed.

Here we will show an example of a quadratic equation to explain the general procedure for solving a high-order equation.

**Example 2:**  $x^2 + 2x - 2 = 0$

(Input/Output: MathI/MathO)

1. Press  $\text{⏏}$ , select the Equation app icon, and then press  $\text{OK}$ .
  - This displays the Equation menu.

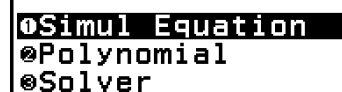

```

0 Simul Equation
1 Polynomial
2 Solver
  
```

2. Select [Polynomial], and then press  $\text{OK}$ .
  - This displays the number of degrees menu.

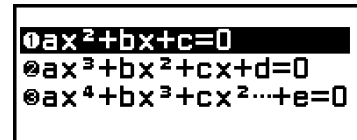

3. Select  $[ax^2+bx+c=0]$ , and then press  $\text{OK}$ .

- This displays the Coefficient Editor.

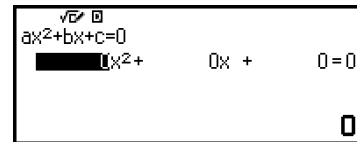

4. Use the Coefficient Editor to input coefficient values.

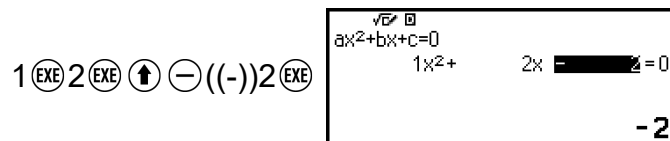

- Pressing  $\text{AC}$  while the Coefficient Editor is displayed will clear all of the coefficients to zero.

5. Press  $\text{EXE}$ .

- This will display a solution.

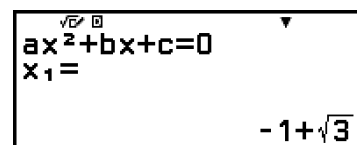

- While the  $\blacktriangledown$  indicator is displayed, each press of  $\text{V}$  (or  $\text{EXE}$ ) will display another calculation result (solution or coordinate).

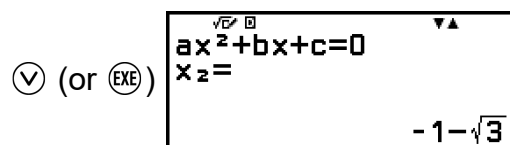

(Displays  $x$ -coordinate of minimum of  $y = x^2 + 2x - 2$ .)

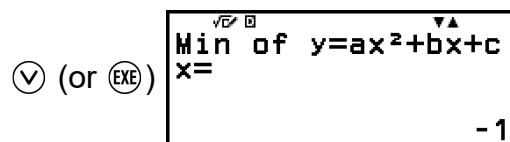

(Displays  $y$ -coordinate of minimum of  $y = x^2 + 2x - 2$ .)

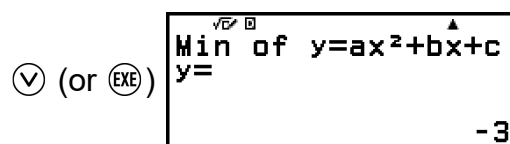

- Pressing  $\text{A}$  or  $\text{B}$  while the  $\blacktriangle$  indicator is displayed causes the previously displayed calculation result to appear again.

- Pressing  $\text{EXE}$  while the final calculation result is displayed returns to the Coefficient Editor. To return to the Coefficient Editor while any calculation result is displayed, press  $\text{AC}$ .
- Pressing  $\text{D}$  while the Coefficient Editor is displayed returns to the number of degrees menu.

### Note

- While the Coefficient Editor is displayed, you can store the currently highlighted value to a variable. Also, while a calculation result (solution or coordinate) is displayed, it can be stored to a variable. For details about variables, see "[Variables \(A, B, C, D, E, F, x, y, z\)](#)" (page 43).

## Complex Number Solution Display (Complex Roots)

High-order equations may have complex number solutions. When Polynomial is selected on the Equation menu, you can use the operations below to enable or disable complex number solution display.

$\text{On}$  – [Complex Roots] > [On]  $\text{AC}$   
Enables complex number solution display.

$\text{Off}$  – [Complex Roots] > [Off]  $\text{AC}$   
Disables complex number solution display (initial default setting).  
Inputting and executing an equation that has one or more complex number solutions only will cause the message "No Real Roots" to appear.

**Example 3:**  $2x^2 + 3x + 4 = 0$

(Input/Output: MathI/MathO, Complex Result:  $a+bi$ , Complex Roots: On)

1. Press  $\text{D}$ , select the Equation app icon, and then press  $\text{OK}$ .
  - This displays the Equation menu.

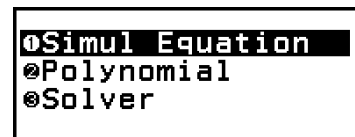

2. Select [Polynomial] > [ $ax^2+bx+c=0$ ].
  - This displays the Coefficient Editor.

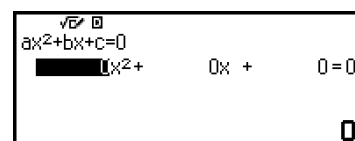

3. Use the Coefficient Editor to input coefficient values.

2  $\text{\textcircled{EXE}}$  3  $\text{\textcircled{EXE}}$  4  $\text{\textcircled{EXE}}$

4. Press  $\text{\textcircled{EXE}}$ .

- This will display a solution.

5. Display another solution and coordinate values.

$\text{\textcircled{V}}$  (or  $\text{\textcircled{EXE}}$ )

$\text{\textcircled{V}}$  (or  $\text{\textcircled{EXE}}$ )

$\text{\textcircled{V}}$  (or  $\text{\textcircled{EXE}}$ )

- Pressing  $\text{\textcircled{EXE}}$  while the final calculation result is displayed returns to the Coefficient Editor. To return to the Coefficient Editor while any calculation result is displayed, press  $\text{\textcircled{AC}}$ .

## Converting a Complex Number Solution to Rectangular or Polar Coordinates

You can use the FORMAT menu that appears when you press  $\text{\textcircled{\uparrow}}$   $\text{\textcircled{FORMAT}}$   $\text{\textcircled{\rightleftarrows}}$  to convert a complex number solution to rectangular coordinate or polar coordinate format.

**Example 4:** To convert the complex number solution displayed in **Example 3 (page 101)** to polar coordinate format and then to rectangular coordinate format

1. Perform steps 1 to 4 of **Example 3 (page 101)**.

2. Press  $\text{\textcircled{\uparrow}}$   $\text{\textcircled{FORMAT}}$   $\text{\textcircled{\rightleftarrows}}$ , select [Polar Coord], and then press  $\text{\textcircled{OK}}$ .

- This converts the solution to polar coordinate format.

- Press  $\uparrow$   $\text{FORM}$   $\text{C}$ , select [Rectangular Coord], and then press  $\text{OK}$ .
  - This converts the solution to rectangular coordinate format.

## Using Solver

Solver uses Newton's method to approximate the solution of equations.

Solver supports input of equations of the following formats.

Examples:  $y = x + 5$ ,  $x = \sin(A)$ ,  $xy + C$  (Treated as  $xy + C = 0$ )

**Example 5:** To solve  $x^2 - \frac{B}{2} = 0$  for  $x$  when  $B = 4$

(Input/Output: MathI/MathO)

### Note

- Before solving  $x^2 - \frac{B}{2} = 0$  for  $x$ , 4 needs to be stored to variable B. This is done in step 3 of the procedure below.

- Press  $\text{MODE}$ , select the Equation app icon, and then press  $\text{OK}$ .
  - This displays the Equation menu.
- Select [Solver], and then press  $\text{OK}$ .
  - This displays the Solver equation input screen.
- Here, store 4 to variable B.

- This operation can be executed at any point before step 7 of this procedure.
  - For details about variables, see "**Variables (A, B, C, D, E, F, x, y, z)**" (page 43).
  - Press  $\text{MODE}$  to return to the Solver equation input screen.
- Input the equation.

\* You can also use the following operation to input = sign:  $\text{Ⓜ}$  –  
 [Equation] > [=].

5. Press  $\text{EXE}$  to register the input equation.
6. On the Solve Target screen that appears, confirm that [x] is selected and then press  $\text{OK}$ .
  - This displays a screen with the initial value of  $x$ .

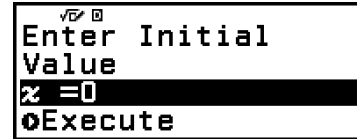

7. Input 1 as the initial value of  $x$ .



8. After making sure that [Execute] is selected, press  $\text{EXE}$  to solve the equation.

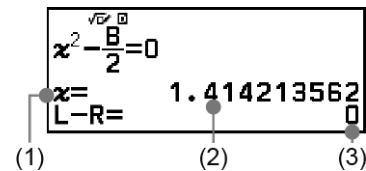

- (1) Variable solved for
- (2) Solution
- (3) (Left Side) – (Right Side) result

- Solutions are always displayed in decimal form.
- The closer the (Left Side) – (Right Side) result is to zero, the higher the accuracy of the solution.

9. Next, press the key that performs the operation you want.

To do this:	Press this key:
Return to the screen in step 6.	$\text{↶}$ *
Store the input expression and return to the screen in step 4.	$\text{EXE}$ or $\text{AC}$

\* The initial value when you press this key becomes the initial value you last used for the calculation.

## Important!

- Solver performs convergence a preset number of times. If it cannot find a solution, it displays a confirmation screen like the one nearby, asking if you want to continue. Press  $\text{OK}$  while [Continue] is selected to continue or select [Exit] and then  $\text{OK}$  to cancel the Solver operation.



$x = 2.728484 \times 10^{-12}$   
 $L-R = 7.444625 \times 10^{-24}$   
Continue  
Exit

- Depending on what you input for the initial value for the solution variable ( $x$  in the above example), Solver may not be able to obtain a solution. If this happens, try changing the initial value so it is closer to the solution.
- Solver may not be able to determine the correct solution, even when one exists.
- Solver uses Newton's method, so even if there are multiple solutions, only one of them will be returned.
- Due to limitations in Newton's method, solutions tend to be difficult to obtain for equations like the following:  $y = \sin x$ ,  $y = e^x$ ,  $y = \sqrt{x}$ .

## Inequality Calculations

You can use the Inequality app to solve a 2nd, 3rd, or 4th degree inequality.

### General Procedure for Performing an Inequality Calculation

**Example 1:** To solve  $x^2 + 2x - 3 \geq 0$

1. Press  $\text{2ND}$ , select the Inequality app icon, and then press  $\text{OK}$ .
  - This displays the number of degrees menu.



1  $ax^2+bx+c$   
2  $ax^3+bx^2+cx+d$   
3  $ax^4+bx^3+cx^2+dx+e$

2. Select [ $ax^2+bx+c$ ], and then press  $\text{OK}$ .



1  $ax^2+bx+c > 0$   
2  $ax^2+bx+c < 0$   
3  $ax^2+bx+c \geq 0$   
4  $ax^2+bx+c \leq 0$

3. On the menu that appears, select the inequality symbol type and orientation ( $>$ ,  $<$ ,  $\geq$ ,  $\leq$ ).
  - Here we want to solve  $x^2 + 2x - 3 \geq 0$ , select [ $ax^2+bx+c \geq 0$ ] and then press  $\text{OK}$ .
4. On the Coefficient Editor that appears, input coefficient values.

1  $\text{EXE}$  2  $\text{EXE}$   $\uparrow$   $\ominus$   $((-))$  3  $\text{EXE}$

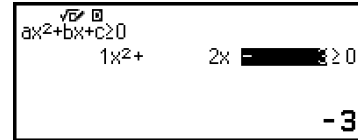

5. Press  $\text{EXE}$ .

- This will display the solution.

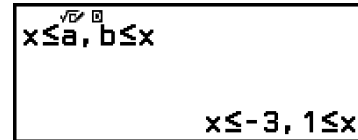

- To return to the Coefficient Editor while the solution is displayed, press  $\text{D}$ ,  $\text{AC}$ , or  $\text{EXE}$ .
- Pressing  $\text{D}$  while the Coefficient Editor is displayed returns to the menu in step 2.
- Pressing  $\text{D}$  while the menu in step 2 is displayed returns to the number of degrees menu.

### Note

- Solutions are displayed as shown in the screen below when something other than MathI/MathO is selected for the Input/Output setting on the SETTINGS menu.



- "No Solution" appears on the solution screen when no solution exists for an inequality (such as  $x^2 < 0$ ).
- "All Real Numbers" appears on the solution screen when the solution of an inequality is all numbers (such as  $x^2 \geq 0$ ).

## Distribution Calculations

In the Distribution app, you can obtain the probability value by selecting the distribution calculation type and inputting various parameters.\* Executable distribution calculation types are shown in the table below.

Distribution Calculation Type	Menu Item
Binomial probability	Binomial PD
Binomial cumulative probability	Binomial CD
Normal probability density	Normal PD

Normal cumulative probability	Normal CD
Inverse normal cumulative distribution*	Inverse Normal
Poisson probability	Poisson PD
Poisson cumulative probability	Poisson CD

\* "Inverse Normal" performs inverse calculation to determine the data value ( $xInv$ ) from a probability value (Area).

## General Procedure for Performing a Distribution Calculation

**Example:** To calculate binomial cumulative probability for the  $x$  data {2, 3, 4, 5} when  $N$  (number of trials) = 5 and  $p$  (probability of success) = 0.5

1. Press  $\Delta$ , select the Distribution app icon, and then press  $\text{OK}$ .
  - This displays the distribution calculation type menu.

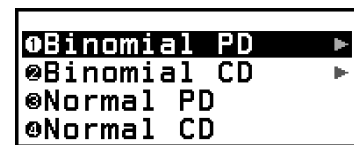

2. On the menu, select a distribution calculation type.
  - Here we want to calculate binomial cumulative probability. Select [Binomial CD], and then press  $\text{OK}$ .
3. On the menu that appears, select a data ( $x$ ) input method.



[List] ... Select to input multiple  $x$ -data items at the same time. Selecting this menu item causes the list screen to appear.

[Variable] ... Select to input a single  $x$ -data item. Selecting this menu item causes a parameter input screen to appear.

- Here we want to input multiple  $x$ -data items at the same time, select [List] and then press  $\text{OK}$ .

4. On the list screen, input  $x$  data {2, 3, 4, 5}.

2  $\text{EXE}$  3  $\text{EXE}$  4  $\text{EXE}$  5  $\text{EXE}$

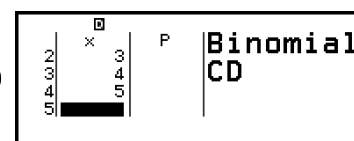

5. Press  $\text{OK}$ .
  - This displays the Binomial CD parameter input screen.

6. Input values for the parameters ( $N = 5, p = 0.5$ ).



- The parameters that require data input depend on the calculation type you selected in step 2 of this procedure. For details, see the **"Parameter List" (page 108)**.
7. After inputting values for all of the parameters, select [Execute] and then press **OK**.
- This displays the calculation result screen.

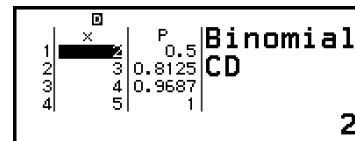

- If you selected [List] in step 3, calculation results (P column) will appear on the list screen. For details, see **"List Screen" (page 109)**.
- If you perform any editing operation (see **"Editing the List Screen Contents" (page 110)**) on the list screen while calculation results are displayed, all the calculation results will be cleared. The list will return to its state in step 4 (list screen data input complete) of this procedure.
- An error message appears if the input value is outside the allowable range. "ERROR" will appear in the P column of the calculation result screen when the value input for the corresponding data is outside the allowable range.
- Pressing **OK** while the calculation result screen is displayed will return to the parameter input screen.

### Note

- If you selected Normal PD, Normal CD, or Inverse Normal in step 2 above, the data ( $x$ ) input method is always "Variable" (single  $x$ -data item input). Because of this, the menu in step 3 is not displayed at this time.
- If the data ( $x$ ) input method is "Variable", the calculation result will be stored in Ans memory.
- Distribution calculation accuracy is up to 6 significant digits.

## Parameter List

The list below shows the meanings of the symbols that appear on the parameter input screen.

### Binomial PD, Binomial CD

$x$  ... data

$N$  ... number of trials

$p$  ... probability of success ( $0 \leq p \leq 1$ )

---

### Normal PD

$x$  ... data

$\mu$  ... population mean

$\sigma$  ... population standard deviation ( $\sigma > 0$ )

---

### Normal CD

Lower ... lower boundary

Upper ... upper boundary

$\mu$  ... population mean

$\sigma$  ... population standard deviation ( $\sigma > 0$ )

---

### Inverse Normal

Area ... probability value ( $0 \leq \text{Area} \leq 1$ )

$\mu$  ... population mean

$\sigma$  ... population standard deviation ( $\sigma > 0$ )

(This function returns the upper limit value  $x_{\text{Inv}}$  when the left tail of a normal distribution is the lower limit.)

---

### Poisson PD, Poisson CD

$x$  ... data

$\lambda$  ... mean

---

#### Note

- The last value input for each parameter name is retained, regardless of the input screen where it is input. For example, inputting a value for  $N$  on the Binomial PD parameter input screen will also change the value of  $N$  on the Binomial CD parameter input screen.
- The values you input for each of the parameters are retained as long as you do not execute either of the following operations:  $\text{☰} - [\text{Reset}] > [\text{Settings \& Data}]$  or  $\text{☰} - [\text{Reset}] > [\text{Initialize All}]$ .

## List Screen

You can use the list screen to input up to 45  $x$ -data items. Calculation results are also displayed on the list screen.

The screenshot shows a list screen for Binomial CD. It features a table with two columns: 'x' and 'P'. The table contains four rows of data. To the right of the table, the text 'Binomial CD' is displayed. There are four callout markers: (1) points to the distribution type text, (2) points to a '2' in the bottom right corner, (3) points to the 'x' column header, and (4) points to the 'P' column header.

	x	P
1	2	0.5
2	3	0.8125
3	4	0.9687
4	5	1

Binomial CD

2

(3) (4)

(1) Distribution calculation type

- (2) Value at current cursor position
- (3) Data ( $x$ )
- (4) Calculation results (P)

### Note

- On the list screen, you can store the value in a cell to a variable. For example, performing the following operation while the above screen is displayed will store 1 to variable A:  $\text{[1]} \text{[=]} \text{[A=]} \text{[>]} \text{[Store]}$ . For details about variables, see "**Variables (A, B, C, D, E, F, x, y, z)**" (page 43).
- Performing one of the operations below deletes all  $x$ -data input on the list screen.
  - Returning to the HOME screen and launching another calculator app
  - Executing  $\text{[Delete All]}$  (See "**To delete all list screen contents**" (page 110).)
  - Executing  $\text{[≡]} \text{[Reset]} \text{[>]} \text{[Settings & Data]}$  or  $\text{[≡]} \text{[Reset]} \text{[>]} \text{[Initialize All]}$

## Editing the List Screen Contents

### To change the $x$ data in a cell

On the list screen, move the cursor to the cell containing the data you want to change, input the new data, and then press  $\text{[EXE]}$ .

### To delete a row

On the list screen, move the cursor to the row you want to delete and then press  $\text{[X]}$ .

### To insert a row

1. On the list screen, move the cursor to the row that will be under the row you will insert.
2. Perform the following operation:  $\text{[000]} \text{[Edit]} \text{[>]} \text{[Insert Row]}$ .
  - This inserts a row with 0 input as the initial default value.

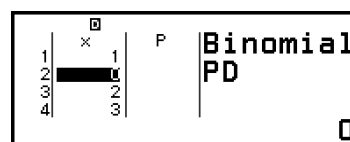

3. Input the data.

### To delete all list screen contents

On the list screen, perform the following operation:  $\text{[000]} \text{[Edit]} \text{[>]} \text{[Delete All]}$ .

## Calculation Example

To calculate the normal probability density when  $x = 36$ ,  $\mu = 35$ ,  $\sigma = 2$

1. Press  $\odot$ , select the Distribution app icon, and then press  $\text{OK}$ .
2. On the distribution calculation type menu that appears, select [Normal PD], and then press  $\text{OK}$ .
  - This displays the Normal PD parameter input screen.
3. Input values for the parameters ( $x = 36$ ,  $\mu = 35$ ,  $\sigma = 2$ ).



4. Press  $\text{OK}$ .

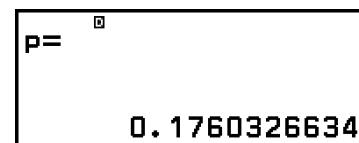

- Pressing  $\text{OK}$  again or pressing  $\odot$  or  $\text{AC}$  returns to the parameter input screen in step 3 of this procedure.
- You can store the currently displayed calculation result to a variable. For example, performing the following operation while the screen in step 4 is displayed above will store the calculation result to variable A:  $\text{STO} \rightarrow \text{A}$  – [A=] > [Store]. For details about variables, see "**Variables (A, B, C, D, E, F, x, y, z)**" (page 43).

## Complex Number Calculations

To perform complex number calculations, first launch the Complex app. Press  $\odot$ , select the Complex app icon, and then press  $\text{OK}$ .

### Inputting Complex Numbers

You can use either rectangular coordinates ( $a+bi$ ) or polar coordinates ( $r\angle\theta$ ) to input complex numbers.

**Example 1:** To input  $2+3i$

2 $\oplus$  3 $\uparrow$   $\text{I}$   $\text{I}^*$  2+3i

\* You can also use the following operation to input  $i$ :  $\text{I}$  – [Complex] > [ $i$ ].

**Example 2:** To input  $5\angle 30$

5  $\text{I}$  – [Complex] > [ $\angle$ ] 30 5 $\angle$ 30

## Complex App Calculation Examples

### Before Performing the Example Operations

- For the examples in this section, use the SETTINGS menu to select MathI/MathO for the Input/Output setting. Configure other settings as shown for each example.
- Complex number calculation results are displayed in accordance with the Complex Result setting on the SETTINGS menu.
- If you are planning to perform input and display of the calculation result in polar coordinate format, specify the Angle Unit on the SETTINGS menu before starting the calculation.
- The  $\theta$  value of the calculation result is displayed in the range of  $-180^\circ < \theta \leq 180^\circ$ .
- Display of the calculation result while something other than MathI/MathO is selected will show  $a$  and  $bi$  (or  $r$  and  $\theta$ ) on separate lines.

**Example 3:**  $(1 + i)^4 + (1 - i)^2 = -4 - 2i$

(Complex Result:  $a+bi$ )

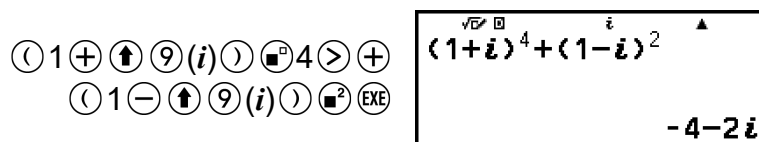

Calculator keypad sequence:  $(1 + i)^4 + (1 - i)^2$

Calculator display:  $(1+i)^4 + (1-i)^2$   
 $-4-2i$

#### Note

- When raising a complex number to an integer power using the syntax  $(a+bi)^n$ , the power value can be within the following range:  $-1 \times 10^{10} < n < 1 \times 10^{10}$ .

**Example 4:**  $2\angle 45 = \sqrt{2} + \sqrt{2}i$

(Angle Unit: Degree, Complex Result:  $a+bi$ )

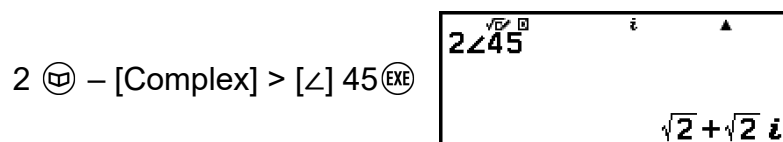

Calculator keypad sequence:  $2 \angle 45$

Calculator display:  $2\angle 45$   
 $\sqrt{2} + \sqrt{2}i$

**Example 5:**  $\sqrt{2} + \sqrt{2}i = 2\angle 45$

(Angle Unit: Degree, Complex Result:  $r\angle\theta$ )

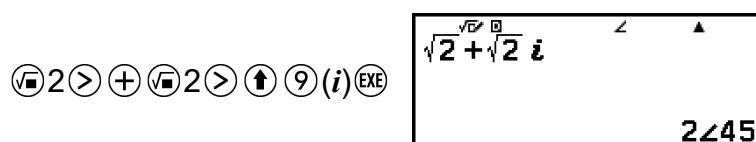

Calculator keypad sequence:  $\sqrt{2} + \sqrt{2}i$

Calculator display:  $\sqrt{2} + \sqrt{2}i$   
 $2\angle 45$

**Example 6:** To obtain the conjugate complex number of  $2 + 3i$

(Complex Result:  $a+bi$ )

$\text{Ⓜ}$  – [Complex] > [Conjugate]  
 $2 \oplus 3 \uparrow \textcircled{9} (i) \textcircled{)} \textcircled{\text{EXE}}$

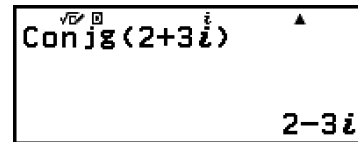

**Example 7:** To obtain the absolute value and argument of  $1 + i$   
 (Angle Unit: Degree)

$\text{Ⓜ}$  – [Numeric Calc] > [Absolute Value]  
 $1 \oplus \uparrow \textcircled{9} (i) \textcircled{\text{EXE}}$

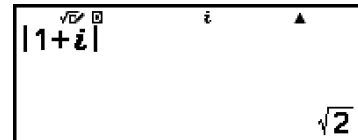

$\text{Ⓜ}$  – [Complex] > [Argument]  
 $1 \oplus \uparrow \textcircled{9} (i) \textcircled{)} \textcircled{\text{EXE}}$

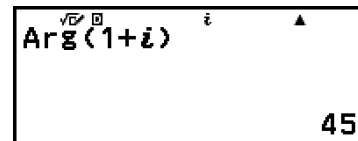

**Example 8:** To extract the real part and imaginary part of  $2 + 3i$

$\text{Ⓜ}$  – [Complex] > [Real Part]  
 $2 \oplus 3 \uparrow \textcircled{9} (i) \textcircled{)} \textcircled{\text{EXE}}$

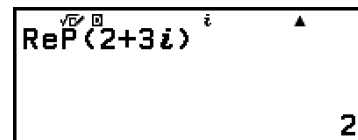

$\text{Ⓜ}$  – [Complex] > [Imaginary Part]  
 $2 \oplus 3 \uparrow \textcircled{9} (i) \textcircled{)} \textcircled{\text{EXE}}$

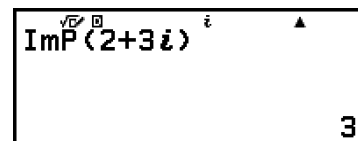

## Converting a Complex Number Calculation Result to Rectangular or Polar Coordinates

You can use the FORMAT menu that appears when you press  $\uparrow \textcircled{\text{FORMAT}} \textcircled{\text{EXE}}$  to convert a complex number calculation result to rectangular coordinate or polar coordinate format.

**Example 9:**  $\sqrt{2} + \sqrt{2}i = 2\angle 45$ ,  $2\angle 45 = \sqrt{2} + \sqrt{2}i$   
 (Angle Unit: Degree, Complex Result:  $a+bi$ )

$\sqrt{\square} 2 \textcircled{>} \oplus \sqrt{\square} 2 \textcircled{>} \uparrow \textcircled{9} (i) \textcircled{\text{EXE}}$

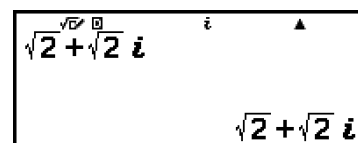

$\uparrow \textcircled{\text{FORMAT}} \textcircled{\text{EXE}}$  – [Polar Coord]

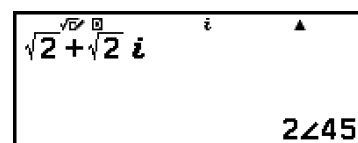

   – [Rectangular Coord]

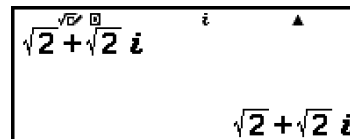

## Matrix Calculations



Use the Matrix app to perform calculations involving matrices of up to 4 rows by 4 columns.

### General Procedure for Performing a Matrix Calculation

To perform a matrix calculation, use the special matrix variables (MatA, MatB, MatC, MatD) as shown in the example below.

**Example 1:** To calculate  $\begin{bmatrix} 2 & 1 \\ 1 & 1 \end{bmatrix} \times \begin{bmatrix} 2 & -1 \\ -1 & 2 \end{bmatrix}$

- For multiplication (Matrix 1  $\times$  Matrix 2), the number of columns in Matrix 1 must match the number of rows in Matrix 2. Otherwise, an error occurs.

1. Press , select the Matrix app icon, and then press .
  - This displays the matrix calculation screen.



2. Press .
  - This displays the matrix variable list screen.

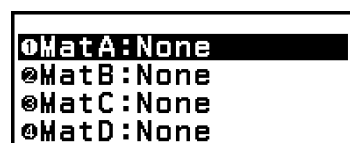

- For details about the matrix variable list screen contents, and how to perform matrix variable store, edit, or other operations, see ["Matrix Variable List Screen" \(page 116\)](#).

3. Perform the steps below to store  $\begin{bmatrix} 2 & 1 \\ 1 & 1 \end{bmatrix}$  to MatA.

- (1) Select [MatA:], and then press .
  - This displays the matrix size setting screen (initial default setting: 2 rows, 2 columns).



- (2) Here, we want to store a 2×2 matrix, so select [Confirm] and then press  $\text{OK}$ .
- This displays the Matrix Editor for input of the elements of the 2×2 matrix for MatA.

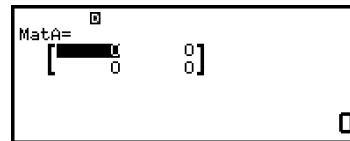

- (3) Input the elements of MatA.

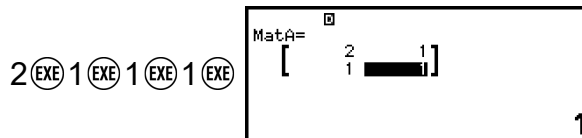

- (4) Press  $\text{↵}$ ,  $\text{AC}$ , or  $\text{OK}$  to return to the matrix calculation screen.

4. Perform the steps below to store  $\begin{bmatrix} 2 & -1 \\ -1 & 2 \end{bmatrix}$  to MatB.

- Press  $\text{○○○}$ , select [MatB:], and then press  $\text{OK}$ .
- Select [Confirm], and then press  $\text{OK}$ .
- Input the elements of MatB.

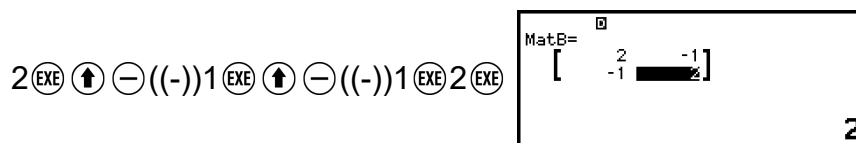

- (4) Press  $\text{↵}$ ,  $\text{AC}$ , or  $\text{OK}$  to return to the matrix calculation screen.

5. Input MatA×MatB.

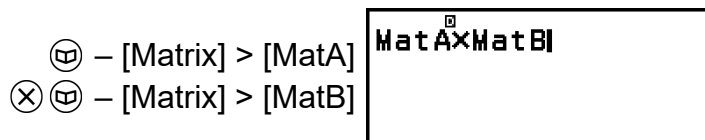

6. Press  $\text{EXE}$ .

- This displays the MatAns (Matrix Answer Memory) screen with the calculation result.

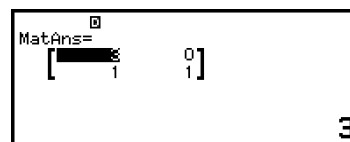

- For details about MatAns, see **"Matrix Answer Memory (MatAns)" (page 118)**.
- Pressing  $\text{AC}$  while the MatAns screen is displayed returns to the matrix calculation screen and clears the calculation expression. Pressing  $\text{↵}$  or  $\text{OK}$  returns to the calculation expression input complete state in step 5 of this procedure.

## Note

- While the Matrix Editor or the MatAns screen is displayed, you can store the currently highlighted value to a variable. While the matrix calculation screen is displayed and a calculation result value is on the screen, you can store the displayed calculation result to a variable. For details about variables, see "[Variables \(A, B, C, D, E, F, x, y, z\)](#)" (page 43).

## Matrix Variable List Screen

The matrix variable list screen is the entry portal you should use when you want to store a matrix into matrix variable MatA, MatB, MatC, or MatD, or to edit a previously stored matrix. The status of each matrix variable is indicated as shown in the examples below.

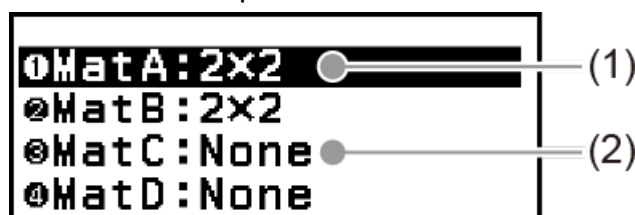

(1) 2×2

Indicates a 2×2 matrix is stored to the matrix variable.

(2) None

Indicates that nothing is stored to the matrix variable.

## Displaying the matrix variable list screen

Depending on the currently displayed screen, perform one of the operations below.

- When the matrix calculation screen is displayed:  
Press  $\odot$ .
- When the Matrix Editor or MatAns screen is displayed:  
Press  $\odot$ , select [Define Matrix], and then press  $\text{OK}$ .

## Storing New Data to a Matrix Variable

**Example 2:** To store the 2×3 matrix  $\begin{bmatrix} 1 & 0 & -1 \\ 0 & -1 & 1 \end{bmatrix}$

1. While the matrix calculation screen is displayed, press  $\odot$  to display the matrix variable list screen.
2. Select the matrix variable (MatA, MatB, MatC, or MatD) to which you want to store new data, and then press  $\text{OK}$ .
  - If you selected a matrix variable whose status is "None", advance to step 4 of this procedure.
  - If you selected a matrix variable that already has a matrix stored to it, a menu screen will appear. Advance to step 3.



3. Select [Define New], and then press  $\text{OK}$ .
4. On the "Matrix Size?" screen that appears, specify the number of rows and columns in the matrix.

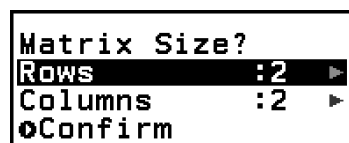

- To specify a 2×3 matrix, perform the steps below.
  - (1) Select [Rows] and then press  $\text{OK}$ . On the menu that appears, select [2 Rows] and then press  $\text{OK}$ .
  - (2) Select [Columns] and then press  $\text{OK}$ . On the menu that appears, select [3 Columns] and then press  $\text{OK}$ .
- 5. After the row and column specifications are the way you want, select [Confirm] and then press  $\text{OK}$ .
  - This displays the Matrix Editor.

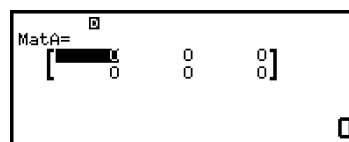

6. Input the elements of the matrix variable.

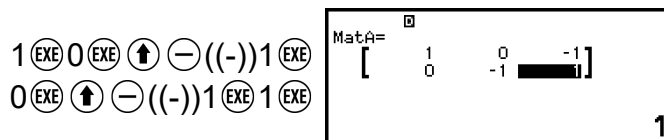

7. Press  $\text{↵}$ ,  $\text{AC}$ , or  $\text{OK}$  to return to the matrix calculation screen.

### Note

- Matrix variable contents are retained even if you press  $\text{↵}$ , change the calculator app, or turn off the calculator. Executing any one of the operations below causes the contents of all matrix variables to be cleared.
  - $\text{☰}$  – [Reset] > [Settings & Data]
  - $\text{☰}$  – [Reset] > [Initialize All]

## Editing Matrix Variable Data

1. While the matrix calculation screen is displayed, press  $\text{☰}$  to display the matrix variable list screen.
2. Select the matrix variable (MatA, MatB, MatC, or MatD) you want to edit, and then press  $\text{OK}$ .

3. On the menu that appears, select [Edit] and then press  $\text{OK}$ .
  - This displays the Matrix Editor.
4. Use the Matrix Editor to edit the elements of the matrix.
  - Move the cursor to the cell that contains the element you want to change, input the new value, and then press  $\text{EXE}$ .
5. Press  $\text{↵}$ ,  $\text{AC}$ , or  $\text{OK}$  to return to the matrix calculation screen.

## Copying Matrix Variable (or MatAns) Contents

1. Display the Matrix Editor or MatAns screen of the matrix variable you want to use as the copy source.
  - To display the Matrix Editor, perform steps 1, 2, and 3 under "**Editing Matrix Variable Data**" (page 117).
  - To display the MatAns screen, perform the steps below while the matrix calculation screen is displayed.
    - $\text{☞}$  – [Matrix] > [MatAns]  $\text{EXE}$
2. Select the matrix variable copy destination.
  - For example, to copy to MatD, perform the following operation:  $\text{☞}$  – [Store] > [MatD].
  - This displays the Matrix Editor with the contents of the copy destination.
3. Press  $\text{↵}$ ,  $\text{AC}$ , or  $\text{OK}$  to return to the matrix calculation screen.

## Matrix Answer Memory (MatAns)

Whenever the result of a calculation executed in the Matrix app is a matrix, the MatAns screen will appear with the result. The result also will be stored to a variable named "MatAns".

The MatAns variable can be used in calculations as described below.

- To insert the MatAns variable into a calculation, perform the following operation:  $\text{☞}$  – [Matrix] > [MatAns].
- Pressing any one of the following keys while the MatAns screen is displayed switches automatically to the matrix calculation screen, with "MatAns" followed by the operator or function of the key you pressed:  $\text{+}$ ,  $\text{-}$ ,  $\text{×}$ ,  $\text{÷}$ ,  $\text{=}$ ,  $\text{□}^{\text{□}}$ ,  $\text{□}^2$ ,  $\text{↑}$   $\text{√}$  ( $\text{√}$ ),  $\text{↑}$   $\text{□}^{\text{□}}$  ( $\text{□}^{-1}$ ).

### Note

- MatAns contents are retained even if you press  $\text{☰}$  or turn off the calculator. Performing any one of the operations below causes the MatAns contents to be cleared.
  - Returning to the HOME screen and launching another calculator app
  - Executing  $\text{☞}$  – [Reset] > [Settings & Data]
  - Executing  $\text{☞}$  – [Reset] > [Initialize All]

## Matrix Calculation Examples

The examples below use  $\text{MatA} = \begin{bmatrix} 2 & 1 \\ 1 & 1 \end{bmatrix}$ ,  $\text{MatB} = \begin{bmatrix} 2 & 3 \\ 2 & 1 \end{bmatrix}$ ,  $\text{MatC} = \begin{bmatrix} 1 & 0 & -1 \\ 0 & -1 & 1 \end{bmatrix}$ ,  $\text{MatD} = \begin{bmatrix} 1 & 2 & 3 \\ 4 & 5 & 6 \\ 7 & 8 & 9 \end{bmatrix}$ .

**Example 3:** To add two matrices ( $\text{MatA} + \text{MatB}$ )

$\text{MatAns} = \text{MatA} + \text{MatB}$   
 $\text{MatAns} = \begin{bmatrix} 4 & 4 \\ 3 & 2 \end{bmatrix}$

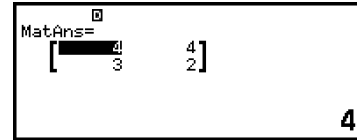

### Note

- The two matrices must have the same dimensions in order to be added or subtracted. An error occurs if you try to add or subtract matrices of different dimensions.

**Example 4:** To square and cube  $\text{MatA}$  ( $\text{MatA}^2$ ,  $\text{MatA}^3$ )

$\text{MatAns} = \text{MatA}^2$   
 $\text{MatAns} = \begin{bmatrix} 3 & 3 \\ 3 & 2 \end{bmatrix}$

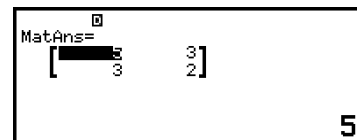

$\text{MatAns} = \text{MatA}^3$   
 $\text{MatAns} = \begin{bmatrix} 8 & 8 \\ 8 & 5 \end{bmatrix}$

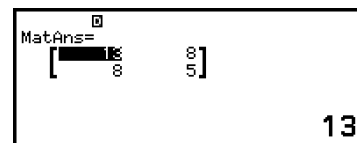

**Example 5:** To invert  $\text{MatA}$  ( $\text{MatA}^{-1}$ )

$$[a_{11}]^{-1} = \frac{1}{a_{11}}$$

$$\begin{bmatrix} a_{11} & a_{12} \\ a_{21} & a_{22} \end{bmatrix}^{-1} = \frac{\begin{bmatrix} a_{22} & -a_{12} \\ -a_{21} & a_{11} \end{bmatrix}}{a_{11}a_{22} - a_{12}a_{21}}$$

$$\begin{bmatrix} a_{11} & a_{12} & a_{13} \\ a_{21} & a_{22} & a_{23} \\ a_{31} & a_{32} & a_{33} \end{bmatrix}^{-1} = \frac{\begin{bmatrix} a_{22}a_{33} - a_{23}a_{32} & -a_{12}a_{33} + a_{13}a_{32} & a_{12}a_{23} - a_{13}a_{22} \\ -a_{21}a_{33} + a_{23}a_{31} & a_{11}a_{33} - a_{13}a_{31} & -a_{11}a_{23} + a_{13}a_{21} \\ a_{21}a_{32} - a_{22}a_{31} & -a_{11}a_{32} + a_{12}a_{31} & a_{11}a_{22} - a_{12}a_{21} \end{bmatrix}}{\det \begin{bmatrix} a_{11} & a_{12} & a_{13} \\ a_{21} & a_{22} & a_{23} \\ a_{31} & a_{32} & a_{33} \end{bmatrix}}$$





- For details about the vector variable list screen contents, and how to perform vector variable store, edit, or other operations, see "**Vector Variable List Screen**" (page 123).

3. Perform the steps below to store (1, 2) to VctA.

(1) Select [VctA:], and then press  $\text{OK}$ .

- This displays the vector dimension setting screen (initial default setting: 2 dimensions).

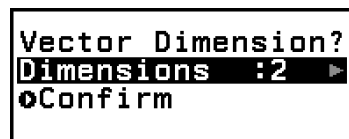

(2) Here, we want to store a two-dimensional vector, so select [Confirm] and then press  $\text{OK}$ .

- This displays the Vector Editor for input of the two-dimensional vector for VctA.

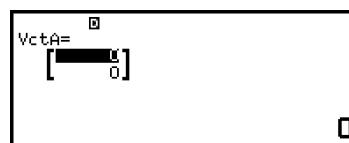

(3) Input the elements of VctA.

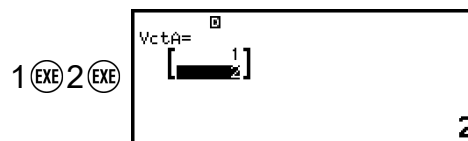

(4) Press  $\text{right arrow}$ ,  $\text{AC}$ , or  $\text{OK}$  to return to the vector calculation screen.

4. Perform the steps below to store (3, 4) to VctB.

(1) Press  $\text{VctB}$ , select [VctB:], and then press  $\text{OK}$ .

(2) Select [Confirm], and then press  $\text{OK}$ .

(3) Input the elements of VctB.

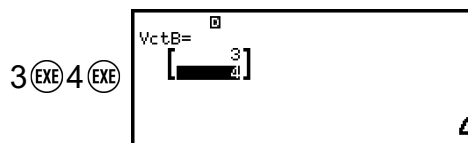

(4) Press  $\text{right arrow}$ ,  $\text{AC}$ , or  $\text{OK}$  to return to the vector calculation screen.

5. Input VctA+VctB.

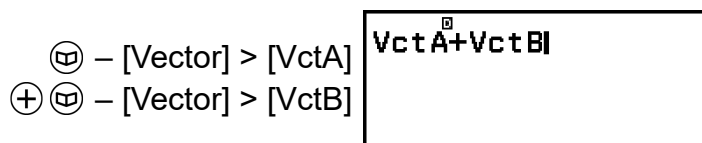

6. Press  $\text{EXE}$ .

- This displays the VctAns (Vector Answer Memory) screen with the calculation result.



- For details about VctAns, see "[Vector Answer Memory \(VctAns\)](#)" ([page 125](#)).
- Pressing  $\text{AC}$  while the VctAns screen is displayed returns to the vector calculation screen and clears the calculation expression. Pressing  $\text{D}$  or  $\text{OK}$  returns to the calculation expression input complete state in step 5 of this procedure.

### Note

- While the Vector Editor or the VctAns screen is displayed, you can store the currently highlighted value to a variable. While the vector calculation screen is displayed and a calculation result value is on the screen, you can store the displayed calculation result to a variable. For details about variables, see "[Variables \(A, B, C, D, E, F, x, y, z\)](#)" ([page 43](#)).

## Vector Variable List Screen

The vector variable list screen is the entry portal you should use when you want to store a vector into vector variable VctA, VctB, VctC, or VctD, or to edit a previously stored vector. The status of each vector variable is indicated as shown in the examples below.

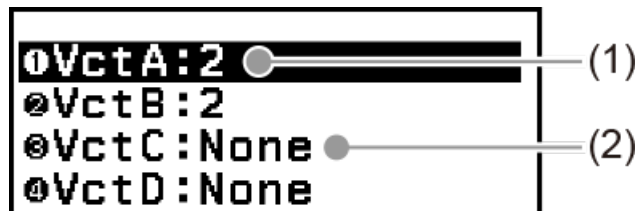

(1) 2

Indicates a two-dimensional vector is stored to the vector variable.

(2) None

Indicates that nothing is stored to the vector variable.

## Displaying the vector variable list screen

Depending on the currently displayed screen, perform one of the operations below.

- When the vector calculation screen is displayed:  
Press  $\text{D}$ .
- When the Vector Editor or VctAns screen is displayed:  
Press  $\text{D}$ , select [Define Vector], and then press  $\text{OK}$ .

## Storing New Data to a Vector Variable

**Example 2:** To store the three-dimensional vector (1, 2, 3)

1. While the vector calculation screen is displayed, press  $\odot$  to display the vector variable list screen.
2. Select the vector variable (VctA, VctB, VctC, or VctD) to which you want to store new data, and then press  $\text{OK}$ .
  - If you selected a vector variable whose status is "None", advance to step 4 of this procedure.
  - If you selected a vector variable that already has a vector stored to it, a menu screen will appear. Advance to step 3.



3. Select [Define New], and then press  $\text{OK}$ .
4. On the "Vector Dimension?" screen that appears, specify the vector dimension.

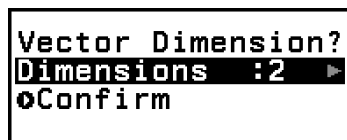

- To specify three dimensions, perform the steps below.
    - (1) Select [Dimensions] and then press  $\text{OK}$ .
    - (2) On the menu that appears, select [3 Dimensions] and then press  $\text{OK}$ .
5. After the dimension specification is the way you want, select [Confirm] and then press  $\text{OK}$ .
    - This displays the Vector Editor.

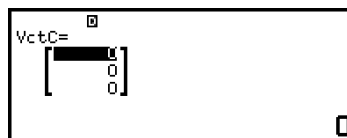

6. Input the elements of the vector variable.

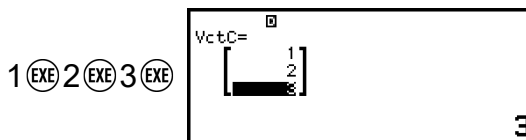







7. Press  $\odot$ ,  $\text{AC}$ , or  $\text{OK}$  to return to the vector calculation screen.

### Note







- Vector variable contents are retained even if you press  $\odot$ , change the calculator app, or turn off the calculator. Executing any one of the operations below causes the contents of all vector variables to be cleared.
  - $\text{☰}$  – [Reset] > [Settings & Data]

## Editing Vector Variable Data

1. While the vector calculation screen is displayed, press  to display the vector variable list screen.
2. Select the vector variable (VctA, VctB, VctC, or VctD) you want to edit, and then press .
3. On the menu that appears, select [Edit] and then press .
  - This displays the Vector Editor.
4. Use the Vector Editor to edit the elements of the vector.
  - Move the cursor to the cell that contains the element you want to change, input the new value, and then press .
5. Press , , or  to return to the vector calculation screen.

## Copying Vector Variable (or VctAns) Contents

1. Display the Vector Editor or VctAns screen of the vector variable you want to use as the copy source.
  - To display the Vector Editor, perform steps 1, 2, and 3 under "**Editing Vector Variable Data**" (page 125).
  - To display the VctAns screen, perform the steps below while the vector calculation screen is displayed.
 











 – [Vector] > [VctAns] 
2. Select the vector variable copy destination.
  - For example, to copy to VctD, perform the following operation:  – [Store] > [VctD].
  - This displays the Vector Editor with the contents of the copy destination.
3. Press , , or  to return to the vector calculation screen.

## Vector Answer Memory (VctAns)

Whenever the result of a calculation executed in the Vector app is a vector, the VctAns screen will appear with the result. The result also will be stored to a variable named "VctAns".

The VctAns variable can be used in calculations as described below.

- To insert the VctAns variable into a calculation, perform the following operation:  – [Vector] > [VctAns].
- Pressing any one of the following keys while the VctAns screen is displayed switches automatically to the vector calculation screen, with "VctAns" followed by the operator or function of the key you pressed:
 

, , , , , , , , , .

### Note

- VctAns contents are retained even if you press  $\text{\textcircled{C}}$  or turn off the calculator.  
Performing any one of the operations below causes the VctAns contents to be cleared.
  - Returning to the HOME screen and launching another calculator app
  - Executing  $\text{\textcircled{=}}$  – [Reset] > [Settings & Data]
  - Executing  $\text{\textcircled{=}}$  – [Reset] > [Initialize All]

## Vector Calculation Examples

The examples below use  $\text{VctA} = (1, 2)$  and  $\text{VctB} = (3, 4)$ , and  $\text{VctC} = (2, -1, 2)$ .

### Example 3: $\text{VctA} \cdot \text{VctB}$ (Vector dot product)

$$(a_1, a_2) \cdot (b_1, b_2) = a_1b_1 + a_2b_2$$

$$(a_1, a_2, a_3) \cdot (b_1, b_2, b_3) = a_1b_1 + a_2b_2 + a_3b_3$$

$\text{\textcircled{=}}$  – [Vector] > [VctA]  
 $\text{\textcircled{=}}$  – [Vector] > [Vector Calc] > [Dot Product]  
 $\text{\textcircled{=}}$  – [Vector] > [VctB]  $\text{\textcircled{EXE}}$

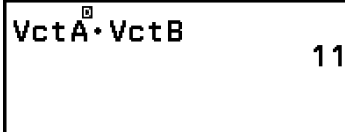

VctA · VctB  
11

### Note

- When calculating a dot product, the dimensions of the two vectors must be the same.

### Example 4: $\text{VctA} \times \text{VctB}$ (Vector cross product)

$$(a_1, a_2) \times (b_1, b_2) = (0, 0, a_1b_2 - a_2b_1)$$

$$(a_1, a_2, a_3) \times (b_1, b_2, b_3)$$

$$= (a_2b_3 - a_3b_2, a_3b_1 - a_1b_3, a_1b_2 - a_2b_1)$$

$\text{\textcircled{=}}$  – [Vector] > [VctA]  
 $\text{\textcircled{=}}$  – [Vector] > [Vector Calc] > [Cross Product]  
 $\text{\textcircled{=}}$  – [Vector] > [VctB]  $\text{\textcircled{EXE}}$

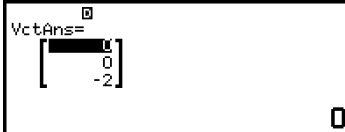

VctAns=  
[ 0  
 0  
 -2 ]  
0

### Note

- When calculating a cross product, the dimensions of the two vectors must be the same.

**Example 5:** To determine the angle formed by  $\text{VctA}$  and  $\text{VctB}$  to three decimal places. (Number Format: Fix 3, Angle Unit: Degree)

$\text{\textcircled{=}}$  – [Vector] > [Vector Calc] > [Angle]  
 $\text{\textcircled{=}}$  – [Vector] > [VctA]  
 $\text{\textcircled{\uparrow}} \text{\textcircled{)}} \text{\textcircled{,}} \text{\textcircled{=}}$  – [Vector] > [VctB]  $\text{\textcircled{)}} \text{\textcircled{EXE}}$



Angle(VctA, VctB)  
10.305

## Note

- When calculating an angle formed by two vectors, the dimensions of the two vectors must be the same.

**Example 6:** To normalize VctB

Ⓜ – [Vector] > [Vector Calc] > [Unit Vector]  
 Ⓜ – [Vector] > [VctB] Ⓜ Ⓜ

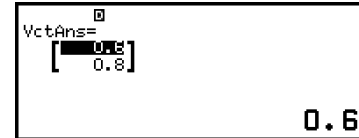

**Example 7:** To obtain the absolute values of VctC

$$\text{Abs}(a_1, a_2) = \sqrt{a_1^2 + a_2^2}$$

$$\text{Abs}(a_1, a_2, a_3) = \sqrt{a_1^2 + a_2^2 + a_3^2}$$

Ⓜ – [Numeric Calc] > [Absolute Value]  
 Ⓜ – [Vector] > [VctC] Ⓜ Ⓜ

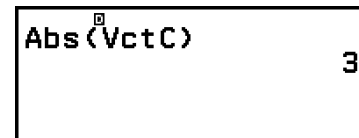

## Using Spreadsheet

The Spreadsheet app makes it possible to perform calculations using a 45-row × 5-column (cell A1 to E45) spreadsheet.

To perform the operations in this section, first launch the Spreadsheet app. Press Ⓜ, select the Spreadsheet app icon, and then press Ⓜ. This displays the spreadsheet screen.

	A	B	C	D
1	170	179	176	176
2	173	175	171	182
3	177	175	175	177
4	520			

=Sum(A1:A3)

- Row numbers (1 to 45)
- Column letters (A to E)
- Cursor: Indicates the currently selected cell. The row number and column letter of the currently selected cell are displayed in black, and the other cell row numbers and column letters are displayed in dark gray.
- Edit box: Shows the contents of the cell where the cursor is currently located.

## Important!

- Any time you turn off the calculator or press the  $\text{OFF}$  key, every input into the spreadsheet is cleared.

## Inputting and Editing Cell Contents

You can input a constant or a formula into each cell.

**Constants:** A constant is something whose value is fixed as soon as you finalize its input. A constant can be either a numeric value, or a calculation expression (such as  $7+3$ ,  $\sin 30$ ,  $A1 \times 2$ , etc.) that does not have an equal sign (=) in front of it.

**Formulas:** A formula that starts with an equal sign (=), such as  $=A1 \times 2$ , is executed as it is written.

### Note

- A maximum of 49 bytes can be input into a cell (number of bytes before the input is confirmed by pressing  $\text{EXE}$ ) that is being edited. How the number of bytes is counted is shown below.
  - Numerals, variables, symbols: 1 byte per character
  - Commands, functions: 1 byte eachEach entire command or function is counted as one byte. For example, the following are one byte: " $\sqrt{\quad}$ ", "Sum(".
- The number of bytes consumed after the input is confirmed is as shown below, according to the contents entered in each cell.
  - Constants: 14 bytes, regardless of the number of input digits\*
  - Formulas: Number of input bytes (49 bytes maximum) + 15 bytes\* If you enter a constant with 11 or more significant digits, the value will be converted to 10 significant digits when the input is confirmed.  
Example: If you input 12345678915 (11 digits), the value will be converted to  $1.234567892 \times 10^{10}$  (10 digits).

## To display the remaining input capacity

Press  $\text{MEM}$ , select [Available Memory], and then press  $\text{OK}$ .

## Inputting a Constant and Formula into a Cell

**Example 1:** Into cells A1, A2, and A3, input constants  $7 \times 5$ ,  $7 \times 6$ , and  $A2+7$  respectively. And then, input the following formula into cell B1:  $=A1+7$ .

1. Move the cursor to cell A1.
2. Perform the key operation below.

$7 \times 5 \text{ EXE } 7 \times 6 \text{ EXE } \uparrow 4 (A) 2 + 7 \text{ EXE}$

	A	B	C	D
1	35			
2	42			
3	49			
4				

3. Move the cursor to cell B1, and then perform the key operation below.

↑ ( (=) ↑ 4 (A) 1 + 7 EXE

	A	B	C	D
1	35	42		
2	42			
3	49			
4				

### Note

- On the spreadsheet screen, you can store the value in a cell to a variable. For example, performing the following operation while the screen in step 3 is displayed will store 42 (calculation result of the formula input into cell B1) to variable A: (↑) (2.30) – [A=] > [Store]. For details about variables, see "[Variables \(A, B, C, D, E, F, x, y, z\)](#)" (page 43).
- You can specify whether a formula in the edit box should be displayed as it is or as its calculation result value. See "[Spreadsheet App Setting Items](#)" (page 134).

### To edit existing cell data

- Move the cursor to the cell whose contents you want to edit, and then press (OK).
  - Instead of pressing (OK), you can also perform the operation below. (○○○) – [Edit Cell]
  - Cell contents in the edit box will change from align right to align left. A text cursor (|) will appear in the edit box so you can edit its contents.
- Use (←) and (→) to move the text cursor around the contents of the cell, and edit them as required.
- To finalize and apply your edits, press (EXE).

### To input a cell reference name using the Grab command

The Grab command can be used in place of manual reference name (such as A1) input using a key operation to select and input a cell you want to reference.

**Example 2:** Continuing from Example 1, input the following formula into cell B2: =A2+7.

- Move the cursor to cell B2.
- Perform the operation below.

↑ ( (=) (☒) – [Spreadsheet] > [Grab] (←)

	A	B	C	D
1	35	42		
2	42			
3	49			
4				

Set : [ OK ]

(OK) (+) 7 (EXE)

	A	B	C	D
1	35	42		
2	42	49		
3	49			
4				

## Cell Relative and Absolute References

There are two types of cell reference: relative and absolute.

### Relative cell reference

The cell reference (A1) in a formula like =A1+7 is a relative reference, which means that it changes depending on the cell where the formula is located. If the formula =A1+7 is originally located in cell B1, for example, copying and then pasting to cell C3 will result in =B3+7 being input into cell C3. Since the copy and paste operation moves the formula one column (B to C) and two rows (1 to 3) the A1 relative cell reference in the formula is moved one column and two rows to B3. If the result of a copy and paste operation causes a relative cell reference name to change to something that is outside the range of the spreadsheet cells, the applicable column letter and/or row number will be replaced by a question mark (?), and "ERROR" will be displayed as the cell's data.

### Absolute cell reference

If you want the row or the column, or both the row and the column parts of a cell reference name to remain the same no matter where you paste them, you need to create an absolute cell reference name. To create an absolute cell reference, put a dollar sign (\$) in front of the column name and/or row number. You can use one of three different absolute cell references: absolute column with relative row (\$A1), relative column with absolute row (A\$1), or absolute row and column (\$A\$1).

### To input the absolute cell reference symbol (\$)

While inputting a formula into a cell, press  $\text{Ⓢ}$  and then select [Spreadsheet] > [\$].

### To cut and paste spreadsheet data

1. Move the cursor to the cell whose data you want to cut.
2. Press  $\text{Ⓞ}$ , select [Cut & Paste], and then press  $\text{Ⓚ}$ .
  - This enters paste standby. To cancel paste standby, press  $\text{Ⓢ}$  or  $\text{Ⓐ}$ .
3. Move the cursor to the cell into which you want to paste the data you just cut, and then press  $\text{Ⓚ}$ .
  - Pasting data simultaneously deletes the data from the cell where you performed the cut operation, and automatically cancels paste standby.

### Note

- In the case of a cut and paste operation, cell references do not change when pasted, regardless of whether they are relative or absolute.

## To copy and paste spreadsheet data

1. Move the cursor to the cell whose data you want to copy.
2. Press  $\odot$ , select [Copy & Paste], and then press  $\text{OK}$ .
  - This causes "Paste:[OK]" to appear at the bottom of the screen. You can continue to paste while this message is displayed.
3. Move the cursor to the cell into which you want to paste the data you just copied.
4. Press  $\text{OK}$ .
  - The contents of the cell you copied are pasted and the cursor moves down to the next cell.
5. If you want to paste the same contents to another cell, repeat steps 3 and 4.
  - If you want to continue pasting to the cell to which the cursor has been moved, just repeat the operation in step 4.
6. To end the paste operation, press  $\rightarrow$  or  $\text{AC}$ .

### Note

- When you copy the contents of a cell containing a formula with a relative reference, the relative reference will change in accordance with the location of the cell where the contents are pasted.

## To delete input data from a specific cell

Move the cursor to the cell whose contents you want to delete and then press  $\text{X}$ .

## To delete the contents of all the cells in a spreadsheet

Press  $\odot$ , select [Delete All], and then press  $\text{OK}$ .

## Using Spreadsheet App Special Commands

In the Spreadsheet app, the commands below can be used inside formulas or constants. These commands are on the menu that appears when you press  $\text{M}$  and then select [Spreadsheet].

---

### Min(

Returns the minimum of the values in a specified range of cells.

Syntax: Min(start cell:end cell)

---

## Max(

Returns the maximum of the values in a specified range of cells.

Syntax: Max(start cell:end cell)

---

## Mean(

Returns the mean of the values in a specified range of cells.

Syntax: Mean(start cell:end cell)

---

## Sum(

Returns the sum of the values in a specified range of cells.

Syntax: Sum(start cell:end cell)

---

**Example 3:** Continuing from Example 1, input the formula =Sum(A1:A3), which calculates the sum of cells A1, A2, and A3, into cell A4.

1. Move the cursor to cell A4.
2. Input =Sum(A1:A3).

↑ ( (=) ⊞ – [Spreadsheet] > [Sum]    ⬆ Ⓞ (A) Ⓛ

⊞ – [Spreadsheet] > [:]    ⬆ Ⓞ (A) Ⓜ Ⓛ

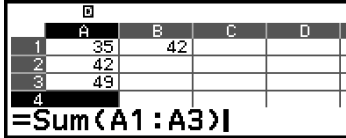

3. Press ⊞.

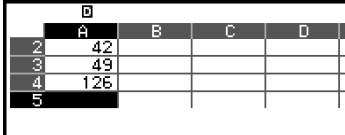

	A	B	C	D
2	42			
3	49			
4	126			
5				

## Batch Inputting the Same Formula or Constant into Multiple Cells

You can use the procedures in this section to input the same formula or constant into a specific series of cells. Use the Fill Formula command to batch input a formula, or Fill Value to batch input a constant.

### Note

- If the input formula or constant includes a relative reference, the relative reference will be input in accordance with the upper-left cell of the specified range. If the input formula or constant includes an absolute reference, the absolute reference will be input into all of the cells in the specified range.

## To batch input the same formula into a series of cells

**Example 4:** Continuing from Example 1, batch input into cells B1, B2, and B3 a formula that doubles the value of the cell to the left and then subtracts 3.

1. Move the cursor to cell B1.
2. Press  $\text{F8}$ , select [Fill Formula], and then press  $\text{OK}$ .
  - This displays a Fill Formula screen.
3. In the "Form" line, input the formula  $=2A1-3$ :  $\text{2}$   $\uparrow$   $\text{4}$   $\text{(A)}$   $\text{1}$   $\text{-}$   $\text{3}$   $\text{EXE}$ .
  - Input of the equals symbol (=) at the beginning is not required.
4. In the "Range" line, specify B1:B3 as the range of the batch input.



5. To apply the input, press  $\text{OK}$ .
  - This inputs  $=2A1-3$  into cell B1,  $=2A2-3$  into cell B2, and  $=2A3-3$  into cell B3.

	A	B	C	D
1	35	67		
2	42	81		
3	49	95		
4				$=2A1-3$

## To batch input the same constant into a series of cells

**Example 5:** Continuing from Example 4, batch input into cells C1, C2, and C3 values that are triple the values in the cells to their left.

1. Move the cursor to cell C1.
2. Press  $\text{F8}$ , select [Fill Value], and then press  $\text{OK}$ .
  - This displays a Fill Value screen.
3. In the "Value" line, input the constant  $B1 \times 3$ :  $\uparrow$   $\text{5}$   $\text{(B)}$   $\text{1}$   $\text{X}$   $\text{3}$   $\text{EXE}$ .
4. In the "Range" line, specify C1:C3 as the range of the batch input.



5. To apply the input, press  $\text{OK}$ .
  - This inputs the values of each calculation result into cells C1, C2, and C3.

	A	B	C	D
1	35	67	201	
2	42	81	243	
3	49	95	285	
4				201

## Spreadsheet App Setting Items

The setting items below are included on the TOOLS menu.

"◆" indicates the initial default setting.

---

### Auto Calc

Specifies whether or not formulas should be re-calculated automatically.

On◆: Enables auto re-calculation.

Off: Disables auto re-calculation.

---

### Show Cell

Specifies whether a formula in the edit box should be displayed as it is or as its calculation result value.

Formula◆: Displays the formula as it is.

Value: Displays the calculation result value of the formula.

---

## Auto Calc and Recalculate

"Auto Calc" is a setting item on the TOOLS menu (see "[Spreadsheet App Setting Items](#)" (page 134)).

With the Spreadsheet app's initial default setting (Auto Calc: On), formulas in a cell are automatically re-calculated each time the cell contents are edited. Depending on the content of the spreadsheet, auto re-calculation can take a long time to complete. When Auto Calc is disabled (Off), you need to execute re-calculation manually as required.

### To execute re-calculation manually

Press  $\odot$ , select [Recalculate], and then press  $\text{OK}$ .

#### Note

- Even if the Auto Calc setting is On, you should execute [Recalculate] in the cases below.
  - When the SETTINGS menu is used to change the Angle Unit setting
  - When a cell contains a formula using the function "f(" or "g(" and the corresponding defining equation ( $f(x)$  or  $g(x)$ ) is updated
  - When a cell contains a formula using a variable and the corresponding variable is updated

## Ratio Calculations

---

The Ratio app lets you determine the value of X in the ratio expression  $A : B = X : D$  (or  $A : B = C : X$ ) when the values of A, B, C and D are known.

## General Procedure for Performing a Ratio Calculation

**Example 1:** To solve  $3 : 8 = X : 12$  for  $X$

1. Press  $\odot$ , select the Ratio app icon, and then press  $\text{OK}$ .
2. On the menu that appears, select [A:B=X:D] or [A:B=C:X].
  - Here we want to solve  $3 : 8 = X : 12$  for  $X$ , select [A:B=X:D], and then press  $\text{OK}$ .
3. On the Coefficient Editor that appears, input coefficient values.
  - Here we input the following for the coefficients:  $A = 3$ ,  $B = 8$ ,  $D = 12$ .

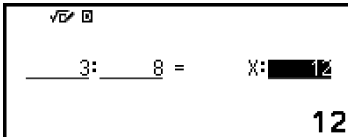
$$3 \text{ (EXE)} 8 \text{ (EXE)} 12 \text{ (EXE)}$$

4. After all the values are the way you want, press  $\text{OK}$ .
  - This displays the solution (value of  $X$ ).



- Press  $\leftarrow$ ,  $\text{AC}$ , or  $\text{OK}$  to return to the Coefficient Editor.

### Note

- A Math ERROR will occur if you perform a calculation while 0 is input for a coefficient.
- Performing the steps below resets all Coefficient Editor coefficients to 1.
  - While the Coefficient Editor is displayed, press  $\leftarrow$ ,  $\text{AC}$ ,  $\odot$ , or  $\downarrow$ .
  - While a solution is displayed, press  $\odot$  or  $\downarrow$ .
- You can store the currently displayed calculation result to a variable. For example, performing the following operation while the screen in step 4 is displayed above will store the calculation result to variable A:  $\text{[Ans]} \rightarrow \text{[A]} > \text{[Store]}$ . For details about variables, see "**Variables (A, B, C, D, E, F, x, y, z)**" (page 43).

### To change the ratio expression type

1. While the Coefficient Editor is displayed, press  $\leftarrow$ .
2. On the menu that appears, select the ratio expression type you want.

## Calculation Example

**Example 2:** To calculate  $X$  in the ratio  $1 : 2 = X : 10$

$$\odot \text{ [Ratio]} > \text{[A:B=X:D]}$$

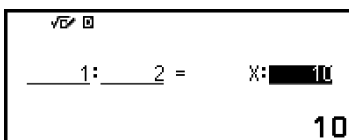
$$1 \text{ (EXE)} 2 \text{ (EXE)} 10 \text{ (EXE)}$$



## Using Math Box

The Math Box app has the following learning support functions.

**Dice Roll:** Dice Roll is function that simulates dice probability.

**Coin Toss:** Coin Toss is a function that simulates coin toss probability.

**Number Line:** Number Line registers up to three equations or inequalities and displays their number lines.

**Circle:** Circle uses a Unit Circle or Half Circle graphic to display angle and trigonometric values. You can also use a Clock graphic to display angles.

### Dice Roll

Dice Roll performs a simulation of one, two, or three virtual dice rolls a specified number of times. You can select either of the following screens for the result.

	A	B	C	Sum
1	1	6	4	11
2	4	3	6	13
3	3	5	1	9
4	1	6	6	13

List screen

Sum	Freq	Rel Fr	Attempts
1	46	0.184	250
2	35	0.14	
3	31	0.124	
4	39	0.156	

**0.184**

Relative Freq screen

### Dice Roll General Operation Procedure

**Example:** To simulate 100 rolls of two dice. For this example, the Relative Freq screen is used for simulation results, showing the number of occurrences (frequencies) and relative frequencies of the numeric difference (0, 1, 2, 3, 4, 5) between the two dice each roll.

- Press  $\odot$ , select the Math Box app icon, and then press  $\text{OK}$ .
  - This displays the Math Box menu.

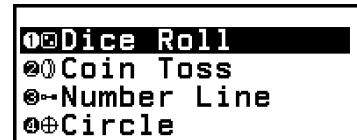

2. Select [Dice Roll], and then press **OK**.
  - This displays the parameter input screen.



Dice: Select the number of dice as 1, 2, or 3.

Attempts: Input the number of dice rolls (number of trials) as a value from 1 to 250.

Same Result: This setting is normally Off (initial default setting). For details, see "[Same Result Setting](#)" (page 139).

3. Select each of the menu settings and configure them the way you want.
  - (1) Select [Dice] and then press **OK**. On the menu that appears, select [Dice] and then press **OK**.
  - (2) Select [Attempts] and then press **OK**. On the input screen that appears, input 100 and then press **OK**. Select [Confirm] and then press **OK**.
  - (3) Leave the [Same Result] set to Off (initial default setting).
4. After all of the settings are the way you want, select [Execute] and then press **OK**.
  - The screen showing execution of the simulation will appear, and then the screen will change to the Result Type menu.

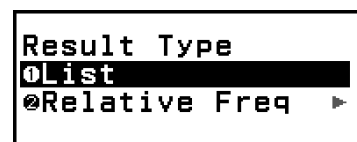

List: Shows a list of the outcome of each roll (trial).<sup>\*1</sup>

Relative Freq: Shows the number of occurrences based on roll results<sup>\*2</sup> and their relative frequencies.

<sup>\*1</sup> When there are two dice, the outcome of each roll is displayed along with each roll's sum and difference. When there are three dice, the outcome of each roll is displayed along with the sum of the roll.

<sup>\*2</sup> Outcome (1 through 6) in the case of one die, sum (2 through 12) or difference (0 through 5) of the outcomes in the case of two dice, and sum (3 through 18) of the outcomes in the case of three dice.

5. Use the Result Type menu to select a result display format.
  - (1) Here, we want to display the number of occurrences and relative frequencies, so select [Relative Freq] and then press **OK**.
    - This displays the [Sum] or [Difference] selection menu.

(2) Here, we want to display the difference in the outcome of each roll, so select [Difference] and then press  $\text{OK}$ .

- The simulation result is displayed on the Relative Freq screen.

Diff	Freq	Rel Fr	Attempts
0	14	0.14	100
1	28	0.28	
2	18	0.18	
3	21	0.21	

**0.14**

(The result differs with each execution.)

- For details about the simulation result screen, see **"Dice Roll Result Screen" (page 138)**.
- To display results using a different format, display the result screen and then press  $\text{↵}$ .
    - This returns to the Result Type menu, so you can repeat step 5 of this procedure and change the result display format.
  - If you want to perform a simulation with different settings, press  $\text{↵}$  while the Result Type menu is displayed.
    - This clears the simulation result and returns to the parameter input screen. Perform the procedure again from step 3.
  - To exit Dice Roll, press  $\text{↵}$  while the parameter input screen is displayed.
    - This returns to the Math Box menu.

### Note

- On the Relative Freq screen, you can store the value in a Rel Fr column cell to a variable. For example, performing the following operation in step 5, above, will store the value in the first row of the "Rel Fr" column to variable A:  $\text{2nd} \rightarrow \text{ALPHA} \rightarrow \text{A} \rightarrow \text{2nd} \rightarrow \text{F1} \rightarrow \text{2nd} \rightarrow \text{F1} \rightarrow \text{2nd} \rightarrow \text{F1}$ . For details about variables, see **"Variables (A, B, C, D, E, F, x, y, z)" (page 43)**.

## Dice Roll Result Screen

- List screen

	(1)	(2)		
			A	B
1	3	6	Sum	Diff
2	5	3	9	3
3	6	3	8	2
4	2	2	9	3
			4	0

- (1) Each row shows a sequential roll number. For example, 1 is the first roll, 2 is the second roll, and so on.
- (2) A, B, and C indicate each of the die being used. "Sum" is for the outcome total, and "Diff" is for the difference between the outcomes

of two dice. The columns that appear on the display depend on how many dice are being used.

- 1 die: A-column only.
- 2 dice: A, B, Sum, and Diff columns.
- 3 dice: A, B, C, and Sum columns.

• Relative Freq screen

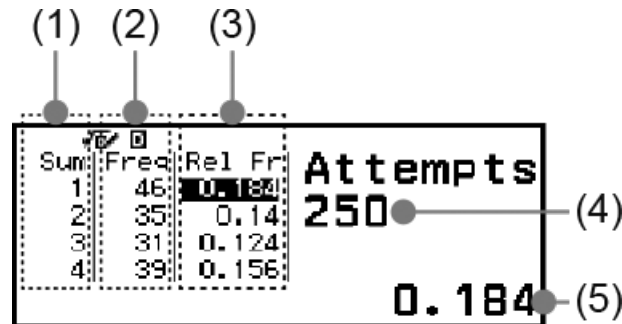

- (1) Sum or Diff: Shows the one die outcome (Sum: 1 through 6), two dice outcome sum (Sum: 2 through 12) or difference (Diff: 0 through 5), or three dice outcome sum (Sum: 3 through 18).
- (2) Freq: Shows the number of occurrences (frequency) of each roll outcome.
- (3) Rel Fr: Shows the relative frequency (frequency divided by number of rolls) of roll results.
- (4) Number of trials
- (5) Highlighted Rel Fr cell's value

### Same Result Setting

When executing a Dice Roll or Coin Toss simulation with Same Result at its initial default setting (Off), each execution displays a different (random) result. If the Same Result setting is changed to something other than Off, the displayed results are those determined by the calculator. Using the #1, #2, or #3 setting is useful when you want the same result to be displayed by all the calculators being used by the students in a class.

#### Note

- To have multiple calculators display the same result, make sure that the settings below are identical on all of the calculators.
  - Number of dice or coins
  - Number of trials (rolls or tosses)
  - Same Result setting (#1, #2, or #3)

## Coin Toss

Coin Toss performs a simulation of one, two, or three virtual coin tosses a specified number of times. You can select either of the following screens for the result.

	A	B	C	
1	○	●	●	2
2	●	●	○	2
3	○	○	●	1
4	○	○	○	0

List screen

Side	Freq	Rel Fr	Attempts
●x0	31	0.124	250
●x1	90	0.36	
●x2	95	0.38	
●x3	34	0.136	
			0.124

Relative Freq screen

The screen shows heads as ● and tails as ○.

### Coin Toss General Operation Procedure

**Example:** To simulate 100 tosses of three coins. For this example, the Relative Freq screen is used for simulation results, showing the number of heads (0, 1, 2, 3) and the relative frequencies of heads of each toss.

- Press  $\Delta$ , select the Math Box app icon, and then press  $\text{OK}$ .
  - This displays the Math Box menu.

$\text{Dice Roll}$
$\text{Coin Toss}$
$\text{-Number Line}$
$\text{Circle}$

- Select [Coin Toss], and then press  $\text{OK}$ .
  - This displays the parameter input screen.

Coins	:1
Attempts	:5
Same Result	:Off
Execute	

Coins: Select the number of coins as 1, 2, or 3.

Attempts: Input the number of coin tosses (number of trials) as a value from 1 to 250.

Same Result: This setting is normally Off (initial default setting). For details, see "[Same Result Setting](#)" (page 139).

3. Select each of the menu settings and configure them the way you want.
  - (1) Select [Coins] and then press **OK**. On the menu that appears, select [3 Coins] and then press **OK**.
  - (2) Select [Attempts] and then press **OK**. When the input screen appears, input 100 and then press **OK**. Select [Confirm] and then press **OK**.
  - (3) Leave the [Same Result] set to Off (initial default setting).
4. After all of the settings are the way you want, select [Execute] and then press **OK**.
  - The screen showing execution of the simulation will appear, and then the screen will change to the Result Type menu.

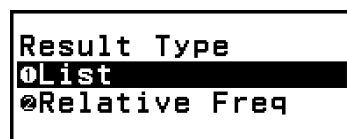

List: Shows a list of heads or tails\*<sup>1</sup> for each toss (trial).

Relative Freq: Shows the number of occurrences for each coin that comes up heads,\*<sup>2</sup> and their relative frequencies.

\*<sup>1</sup> When there are two or three coins, shows the number of coins of each toss that come up heads.

\*<sup>2</sup> For two or three coins. When there is one coin, this shows the frequencies of heads and tails and the relative frequencies.

5. Use the Result Type menu to select a result display format. Here we want to display the number of occurrences and relative frequencies, so select [Relative Freq] and then press **OK**.
  - The simulation result is shown on the Relative Freq screen.

A screenshot of the 'Relative Freq' screen. It displays a table with columns: Side, Freq, and Rel Fr. The 'Attempts' value is 100. The 'Rel Fr' column has a cursor icon next to the value 0.09. The table data is as follows:

Side	Freq	Rel Fr
•x0	9	0.09
•x1	33	0.33
•x2	47	0.47
•x3	11	0.11

The 'Attempts' value is 100. The 'Rel Fr' column has a cursor icon next to the value 0.09.

(The result differs with each execution.)

- For details about the simulation result screen, see **"Coin Toss Result Screen" (page 142)**.
6. To display results using a different format, display the result screen and then press **↶**.
    - This returns to the Result Type menu, so you can repeat step 5 of this procedure and change the result display format.
  7. If you want to perform a simulation with different settings, press **↶** while the Result Type menu is displayed.
    - This clears the simulation result and returns to the parameter input screen. Perform the procedure again from step 3.
  8. To exit Coin Toss, press **↶** while the parameter input screen is displayed.

- This returns to the Math Box menu.

### Note

- On the Relative Freq screen, you can store the value in a Rel Fr column cell to a variable. For example, performing the following operation in step 5, above, will store the value in the first row of the "Rel Fr" column to variable A:  $\text{2nd} \rightarrow [\text{2nd}] - [\text{A=}] > [\text{Store}]$ .

## Coin Toss Result Screen

- List screen

	A	B	C	●
1	○	●	●	2
2	●	●	○	2
3	○	○	●	1
4	○	○	○	0

- (1) Each row shows a sequential toss number. For example, 1 is the first toss, 2 is the second toss, and so on.
- (2) A, B, and C indicate each of the coins being used. When two coins or three coins are being used, the ● column on the right shows the number of coins that came up heads.

- Relative Freq screen

Side	Freq	Rel Fr
●x0	31	0.124
●x1	90	0.36
●x2	95	0.38
●x3	34	0.136

Attempts: 250

0.124

- (1) Side: When using only one coin, "●" indicates heads while "○" indicates tails. When using two or three coins, this column shows the number of heads (0 to 3).
- (2) Freq: Shows the number of occurrences (frequency) of each toss outcome.
- (3) Rel Fr: Shows the relative frequency (frequency divided by number of tosses) of toss results.
- (4) Number of trials
- (5) Highlighted Rel Fr cell's value

## Number Line

Number Line registers up to three equations or inequalities and displays their number line graphs. The expression types that can be selected are shown below.

$$x < a, x \leq a, x = a, x > a, x \geq a, a < x < b, a \leq x < b, a < x \leq b, a \leq x \leq b$$

The values that you input for a and b in the above expressions must be within the ranges defined below.

$$-1 \times 10^{10} \leq a \leq 1 \times 10^{10}$$

$$-1 \times 10^{10} \leq b \leq 1 \times 10^{10}$$

### Number Line General Operation Procedure

**Example:** To register following three inequalities and display their number line graphs:  $x \leq -1.5$ ,  $x > -1.0$ ,  $-2.0 < x \leq -0.5$

- Press  $\odot$ , select the Math Box app icon, and then press  $\text{OK}$ .
  - This displays the Math Box menu.

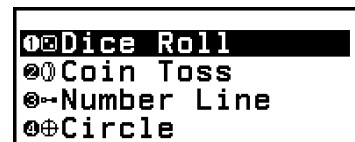

- Select [Number Line], and then press  $\text{OK}$ .
  - This displays the expression registration screen.



- Perform the steps below to register  $x \leq -1.5$  in Line A.
  - Select [A:], and then press  $\text{OK}$ .
  - On the expression type list that appears, select [ $x \leq a$ ] and then press  $\text{OK}$ .

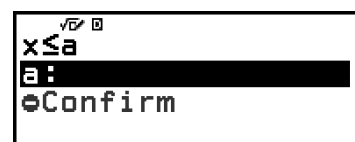

- Input -1.5 for a.

$\uparrow \ominus ((-)) 1 \cdot 5 \text{OK}$

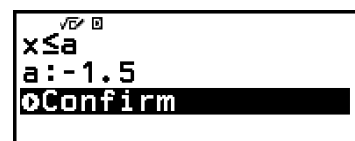

- After making sure that [Confirm] is selected, press  $\text{OK}$ .

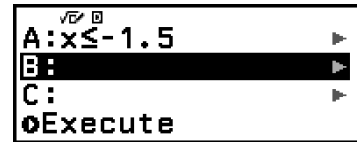

4. Use the steps shown in step 3 to register  $x > -1.0$  in Line B and  $-2.0 < x \leq -0.5$  in Line C.

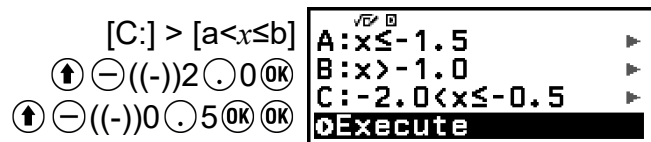
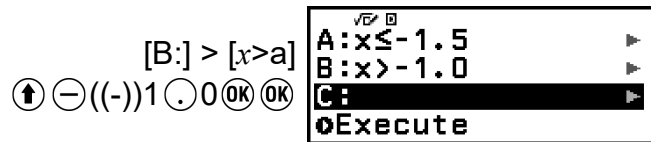

5. After you finish registering all the expressions, select [Execute] on the expression registration screen, and then press  $\odot$ .
- This displays the number line graph screen. You can use  $\leftarrow$  and  $\rightarrow$  to scroll the number line graph left or right.

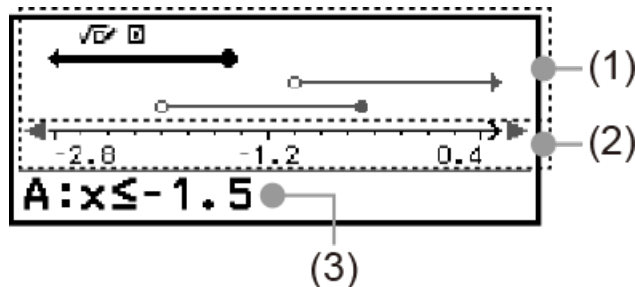

- (1) Shows the number lines of the equations or inequalities registered in lines A, B, and C in sequence from top to bottom. The meanings of the arrows ( $\leftarrow$ ,  $\rightarrow$ ) and circles ( $\bullet$ ,  $\circ$ ) displayed on either end of the number lines are described below.

- $\leftarrow$  Indicates continuation of a range smaller than a in the inequality  $x < a$ , or a range less than or equal to a in  $x \leq a$ .
- $\rightarrow$  Indicates continuation of a range greater than a in the inequality  $x > a$  or a range greater than or equal to a in  $x \geq a$ .
- $\bullet$  Indicates that this value itself (in the case of an equation) or inclusion of this value (in the case of an inequality).
- $\circ$  Indicates non-inclusion of this value (in the case of an inequality).

(2)  $x$ -axis. This shows the center and either end values.

(3) Shows the equations or inequalities of the currently selected number line (the number line displayed in bold). To display a different number line expression, use  $\wedge$  and  $\vee$  to move the bolding to the number line whose expression you want to view.

6. To change the expression, display the number line graph screen and then press  $\odot$ .

- This returns to the expression registration screen. You can change only the values of a registered expression, or you can re-register another type of expression. For information about how to do this, see **"Modifying a Registered Expression" (page 145)**.
7. To exit Number Line, press  $\odot$  on the expression registration screen.
- This clears the registered expression and returns to the Math Box menu.

### Important!

- If you change the Angle Unit setting on the SETTINGS menu, all expressions currently registered in Number Line will be deleted.

## Modifying a Registered Expression

### To modify a registered expression

**Example:** To change the expression in Line C ( $-2.0 < x \leq -0.5$ ) to  $-1.5 < x \leq 0.5$

1. On the expression registration screen, select Line C and then press  $\text{OK}$ .
2. On the menu that appears, select [Edit] and then press  $\text{OK}$ .
3. Input -1.5 for a and 0.5 for b.  
 $\uparrow \ominus ((-)) 1 \cdot 5 \text{OK} 0 \cdot 5 \text{OK}$
4. After making sure that [Confirm] is selected, press  $\text{OK}$ .

### To re-register another type of expression

**Example:** To change the expression in Line A ( $x \leq -1.5$ ) to  $x = -1.5$

1. On the expression registration screen, select Line A and then press  $\text{OK}$ .
2. On the menu that appears, select [Define New] and then press  $\text{OK}$ .
3. On the expression type list that appears, select [ $x=a$ ] and then press  $\text{OK}$ .
4. Input -1.5 for a.  
 $\uparrow \ominus ((-)) 1 \cdot 5 \text{OK}$
5. After making sure that [Confirm] is selected, press  $\text{OK}$ .

### To delete a registered expression

On the expression registration screen, select the registered expression you want to delete, and then press  $\otimes$ .

## Changing the Display Range of the Number Line Graph Screen (View-Window)

When you register an expression and display the number line graph screen, optimal display range settings are configured automatically. You can change the display range by changing Center (1) and Scale (2) settings of the  $x$ -axis. Use the View-Window screen to change display range settings.

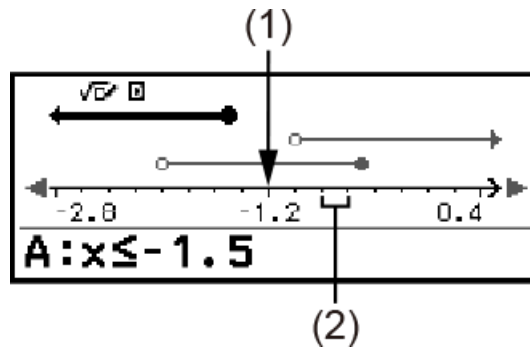

**Example:** To change the  $x$ -axis Scale setting to 1 and the Center setting to 2, and display a number line graph

1. Display the number line graph screen.
2. Press  $\odot$ , select [View-Window], and then press  $\text{OK}$ .
  - This displays the View-Window screen.

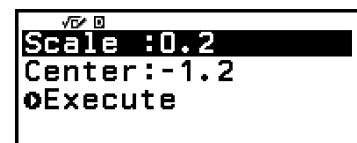

3. Input 1 for [Scale] and 2 for [Center].



4. After making sure that [Execute] is selected, press  $\text{OK}$ .

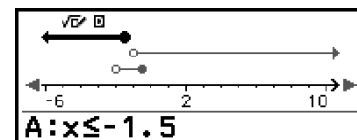

### Note

- The maximum and minimum values for the  $x$ -axis depend on the Center and Scale settings, as shown below.  
 Maximum value:  $(\text{Center Value}) + (\text{Scale Value}) \times 8$   
 Minimum Value:  $(\text{Center Value}) - (\text{Scale Value}) \times 8$
- After changing the View-Window settings, you can restore the Center and Scale settings to their automatically configured display range settings by performing the operation:  $\odot$  – [View-Reset].
- The values that you input for Scale and Center must be within the ranges defined below.  
 $1 \times 10^{-10} \leq \text{Scale} \leq 1 \times 10^{10}$   
 $-1 \times 10^{10} \leq \text{Center} \leq 1 \times 10^{10}$

## Circle

Circle provides the functions described below, which can be used to learn about angles and trigonometric functions.

- **Unit Circle and Half Circle Graphics**

The Unit Circle graphic shows the unit circle with a radius of 1, while the Half Circle graphic shows a half circle with a radius of 1. Both the unit circle and half circle are centered on the origin of rectangular coordinates. The figures below show each type of circle with angles of  $\theta_1$  and  $\theta_2$ , along with trigonometric function values.

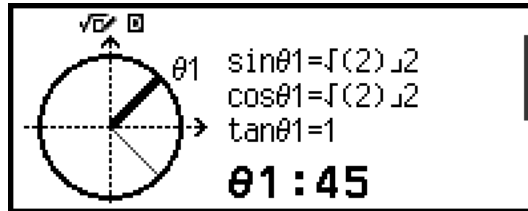

Unit Circle

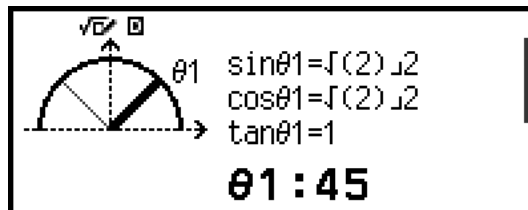

Half Circle

- **Clock Graphic**

The Clock graphic can be used to show the two angles that the hour and minute hands form depending on the time of day. The figure below shows a clock graphic with angles  $\theta_1$  and  $\theta_2$ . In this graphic, the position of the minute hand is fixed at 12 o'clock.

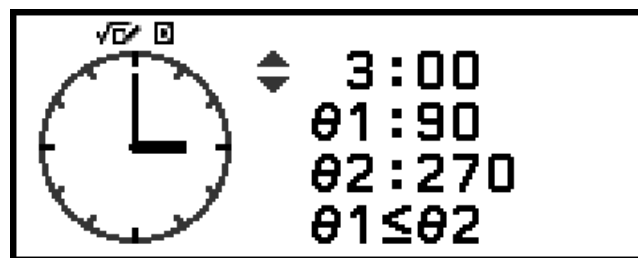

Clock

### Circle General Operation Procedure

1. Press  $\odot$ , select the Math Box app icon, and then press  $\odot$ .
  - This displays the Math Box menu.

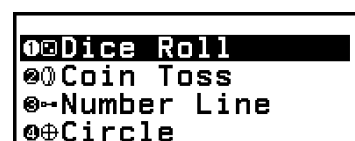

2. Configure the Angle Unit setting as required.
  - You can select any one of the following units for angle value input: Degree, Radian, Gradian. See **"Changing Calculator Settings" (page 24)**.
3. Select [Circle], and then press **OK**.
  - This displays the parameter input screen.



- If you want to select Unit Circle for this procedure, you can proceed directly to step 5. (In this case, press **⏵** to select [θ1] in step 5.)
4. Select the Circle type you want to use.
    - (1) Select [Type], and then press **OK**.
    - (2) On the type list that appears, select [Unit Circle], [Half Circle], or [Clock] and then press **OK**.
      - If you selected [Unit Circle] or [Half Circle], you can proceed directly to step 5.
      - If you selected [Clock], proceed to step 6.
  5. Input the [θ1] and [θ2] angles.
    - When inputting an angle value, use the unit for the currently selected Angle Unit setting.
    - For example, perform the operation below to input 45° for [θ1] and 135° for [θ2] (Angle Unit: Degree).

45 **OK** 135 **OK**

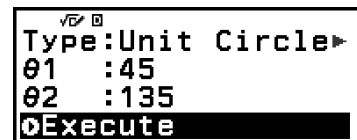

- For the allowable input range for angle values, see the "Note" below.
6. After making sure that [Execute] is selected, press **OK**.
    - This displays the graphic screen.

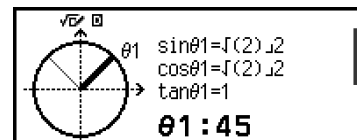

- Refer to the sections below for information about how to view the graphic screen and perform its operations.
    - "Unit Circle and Half Circle Graphic Screens" (page 149)**
    - "Clock Graphic Screen" (page 150)**
7. Press **⏴** to return to the parameter input screen from the graphic screen.
  8. To exit Circle, display the parameter input screen and then press **⏴**.
    - This returns to the Math Box menu.

## Note

- The table below shows the allowable input ranges for values you input in step 5 above.

Angle Unit setting	Unit Circle	Half Circle
Degree	$-10000 < \theta < 10000$	$0 \leq \theta \leq 180$
Radian		$0 \leq \theta \leq \pi^*$
Gradian		$0 \leq \theta \leq 200$

\* 3.1415926535897932384626

## Unit Circle and Half Circle Graphic Screens

The Unit Circle and Half Circle appear as shown below. The sample displays below are for when values for both  $\theta_1$  and  $\theta_2$  have been input.

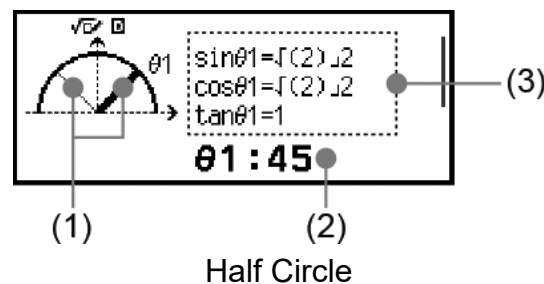
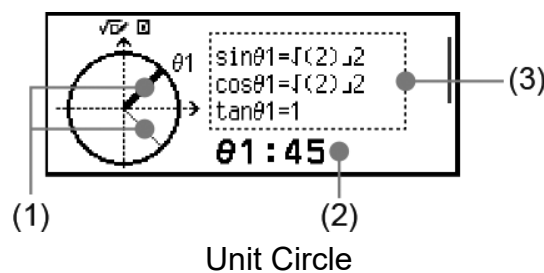

- (1) Lines forming angles  $[\theta_1]$  and  $[\theta_2]$ . The currently selected line is thicker than the other line. You can change the selection between  $\theta_1$  and  $\theta_2$  by pressing  $\wedge$  or  $\vee$ .
- (2) Angle value of the currently selected line's angle ( $\theta_1$  or  $\theta_2$ ).
- (3) Trigonometric function values of the currently selected line's angle ( $\theta_1$  or  $\theta_2$ ).

## Note

- When only a single angle ( $\theta_1$  or  $\theta_2$ ) is input, a single thick line will be displayed to form the angle. In this case, the angle value of the single angle is shown for (2), and trigonometric function values for the angle are shown for (3).

- On the graphic screen, the values of the trigonometric functions are displayed in accordance with the settings of Input/Output and Angle Unit.
- When MathI/MathO or MathI/DecimalO is selected for Input/Output, trigonometric values may include fraction or  $\sqrt{\quad}$  values as applicable.  
Example:  $\sin(45) = \sqrt{2}/2$ ,  $\cos(30) = \sqrt{3}/2$  (Angle Unit: Degree)

## Clock Graphic Screen

The example below shows a typical Clock graphic screen.

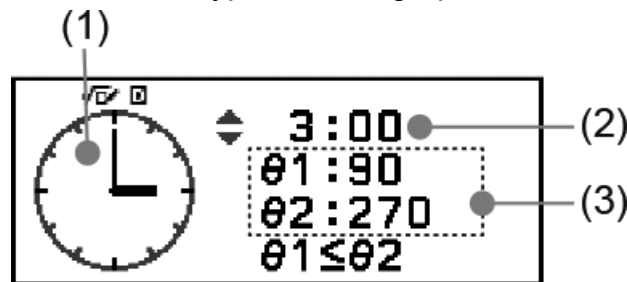

- (1) Clock graphic. The Clock always initially indicates 12 o'clock.  
Press  $\odot$  to advance the hour hand by one hour, or  $\ominus$  to move it back.
- (2) Time indicated by the clock.
- (3)  $\theta_1$ : The smaller angle between the hour and minute hands.  
 $\theta_2$ : The larger angle between the hour and minute hands.

### Note

- Angle values are displayed in accordance with the settings of Input/Output and Angle Unit.
- If Radian is selected for Angle Unit and MathI/MathO is selected for Input/Output, the angle value will be displayed in  $\pi$  format.

## Base- $n$ Calculations

When you want to perform calculations using decimal, hexadecimal, binary, and/or octal values, launch the Base-N app. Press  $\odot$ , select the Base-N app icon, and then press  $\text{OK}$ . The initial default number mode setting when you launch the Base-N app is decimal.

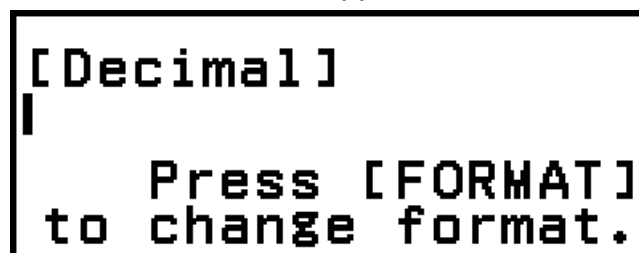

After launching the Base-N app, use  $\text{FORMAT}$  to switch number modes. Each press of  $\text{FORMAT}$  cycles through the number modes as shown below.

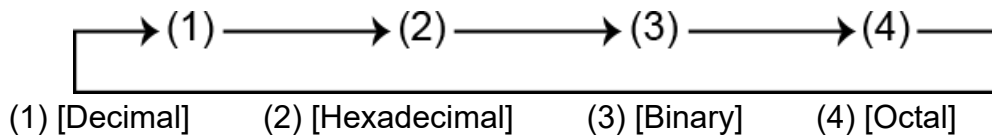

### Note

- The subscripts appended to the values shown in the examples indicate the base (number mode) of each value.

Example:  $1_2$  ... Binary 1;  $1_{16}$  ... Hexadecimal 1

**Example 1:** To calculate  $11_2 + 1_2$

- Use  $\text{FORMAT}$  to change the number mode to [Binary].
- Perform the calculation  $11_2 + 1_2$ .

$$11 \oplus 1 \text{ EXE}$$

[Binary] ▲

11+1

0000 0000 0000 0000

0000 0000 0000 0100

**Example 2:** To calculate  $1F_{16} + 1_{16}$  in hexadecimal

- Use  $\text{FORMAT}$  to change the number mode to [Hexadecimal].
- Perform the calculation  $1F_{16} + 1_{16}$ .

$$1 \uparrow \text{ (F) } \oplus 1 \text{ EXE}$$

[Hexadecimal] ▲

1F+1

00000020

### Note

- Use the following keys to input the letters A through F for hexadecimal values:  $\uparrow$  (4) (A),  $\uparrow$  (5) (B),  $\uparrow$  (6) (C),  $\uparrow$  (1) (D),  $\uparrow$  (2) (E),  $\uparrow$  (3) (F). You can also input hexadecimal values using the CATALOG menu items shown below.  
 $\text{CATALOG}$  – [Hex Value] > [A], [B], [C], [D], [E], or [F]
- Note that if you input any character from A through F using the operation below, the character will be treated as a variable name, and not as a hexadecimal value.
  - Press  $\text{VARIABLE}$  to display the variable list screen.
  - Select [A=], [B=], [C=], [D=], [E=], or [F=], and then press  $\text{OK}$ .
  - On the menu that appears, select [Recall].
- In the Base-N app, input of fractional (decimal) values and exponents is not supported. If a calculation result has a fractional part, it is cut off.
- Details about input and output ranges (32 bits) are shown below.

Base	Range
Binary	Positive: $00000000000000000000000000000000 \leq x \leq 01111111111111111111111111111111$ Negative: $10000000000000000000000000000000 \leq x \leq 11111111111111111111111111111111$
Octal	Positive: $0000000000 \leq x \leq 1777777777$ Negative: $2000000000 \leq x \leq 3777777777$
Decimal	$-2147483648 \leq x \leq 2147483647$
Hexadecimal	Positive: $00000000 \leq x \leq 7FFFFFFF$ Negative: $80000000 \leq x \leq FFFFFFFF$

- A Math ERROR occurs when a calculation result is outside the applicable range for the number system being used.

## Specifying the Number Mode of a Particular Input Value

You can input a special command immediately before a value to specify the number mode of that value. The special commands are: d (decimal), h (hexadecimal), b (binary), and o (octal).

**Example 3:** To calculate  $10_{10} + 10_{16} + 10_2 + 10_8$  and display the result as a decimal value

1. Use  $\text{FORMAT}$  to change the number mode to [Decimal].
2. Perform the calculation  $10_{10} + 10_{16} + 10_2 + 10_8$ .

$\text{FORMAT}$  – [Base Prefix] > [Decimal(d)] 10  $\text{+}$   
 $\text{FORMAT}$  – [Base Prefix] > [Hexadecimal(h)] 10  $\text{+}$   
 $\text{FORMAT}$  – [Base Prefix] > [Binary(b)] 10  $\text{+}$   
 $\text{FORMAT}$  – [Base Prefix] > [Octal(o)] 10  $\text{EXE}$

[Decimal] ▲

d10+h10+b10+o10 36

## Converting a Calculation Result to Another Type of Value

You can use  $\text{FORMAT}$  to convert the currently displayed calculation result to another type of value.

**Example 4:** To calculate  $15_{10} \times 37_{10}$  in the decimal mode, and then convert the result to hexadecimal

1. Use  $\text{FORMAT}$  to change the number mode to [Decimal].
2. Perform the calculation  $15_{10} \times 37_{10}$ .

$15 \text{ X } 37 \text{ EXE}$

[Decimal] ▲

15x37 555

3. Use  $\text{MODE}$  to change the number mode to [Hexadecimal].

```
[Hexadecimal] ^
15x37          0000022B
```

## Logical and Negation Operations

Logical and negation operations are performed by pressing  $\text{MODE}$  and selecting [Logic Operation], and then selecting the desired command (Neg, Not, and, or, xor, xnor) from the menu that appears. All of the examples below are performed in the binary mode.

**Example 5:** To determine the logical AND of  $1010_2$  and  $1100_2$  ( $1010_2$  and  $1100_2$ )

```
1010
MODE - [Logic Operation] > [and]
1100 EXE
```

```
[Binary] ^
1010and1100
0000 0000 0000 0000
0000 0000 0000 1000
```

**Example 6:** To determine the bitwise complement of  $1010_2$  (Not( $1010_2$ ))

```
MODE - [Logic Operation] > [Not]
1010 ) EXE
```

```
[Binary] ^
Not(1010)
1111 1111 1111 1111
1111 1111 1111 0101
```

### Note

- In the case of a negative binary, octal or hexadecimal value, the calculator converts the value to binary, takes the two's complement, and then converts back to the original number base. For decimal values, the calculator merely adds a minus sign.

# Technical Information

---

## Errors

---

The calculator will display an error message whenever an error occurs for any reason during a calculation.

### Displaying the Location of an Error

While an error message is displayed, pressing  $\text{OK}$ ,  $\text{↵}$ , or  $\text{AC}$  returns to the screen that was displayed immediately before the error message appeared. The cursor will be positioned at the location where the error occurred, ready for input. Make the necessary corrections to the calculation and execute it again.

**Example:** When you input  $14 \div 0 \times 2$  by mistake instead of  $14 \div 10 \times 2$ .

The diagram shows three stages of calculator operation:

- Stage 1:** The user inputs  $14 \div 0 \times 2$  and presses  $\text{EXE}$ . The calculator screen displays "Math ERROR" with a warning triangle icon and a "Back" button at the bottom.
- Stage 2:** Pressing  $\text{OK}$  (or  $\text{↵}$  or  $\text{AC}$ ) returns the calculator to the input screen, which now shows  $14 \div 0 \times 2$ .
- Stage 3:** Pressing the left arrow key ( $\text{←}$ ) moves the cursor to the "0" in the denominator, and pressing  $\text{EXE}$  again executes the corrected calculation  $14 \div 10 \times 2$ , resulting in the fraction  $\frac{14}{5}$ .

### Error Messages

---

#### Syntax ERROR

**Cause:**

- There is a problem with the format of the calculation you are performing.

**Action:**

- Make necessary corrections.

---

#### Math ERROR

**Cause:**

- The intermediate or final result of the calculation you are performing exceeds the allowable calculation range.

- Your input exceeds the allowable input range (particularly when using functions).
- The calculation you are performing contains an illegal mathematical operation (such as division by zero).
- While using an app that does not support complex numbers or while a screen that does not accept input of complex numbers is displayed, you attempted to execute a calculation that includes a variable where a complex number is stored.

**Action:**

- Check the input values, reduce the number of digits, and try again.
  - When using a variable as the argument of a function, make sure that the variable value is within the allowable range for the function.
  - To execute a calculation that includes a variable where a complex number is stored, while using an app that does not support complex numbers or while a screen that does not accept input of complex numbers is displayed, change the value stored to the variable to a real number.
- 

## **Stack ERROR**

**Cause:**

- The calculation you are performing has caused the capacity of the numeric stack or the command stack to be exceeded.
- The calculation you are performing has caused the capacity of the matrix or vector stack to be exceeded.

**Action:**

- Simplify the calculation expression so it does not exceed the capacity of the stack.
  - Try splitting the calculation into two or more parts.
- 

## **Argument ERROR**

**Cause:**

- There is a problem with the argument of the calculation you are performing.

**Action:**

- Make necessary corrections.
- 

## **Dimension ERROR (Matrix and Vector apps only)**

**Cause:**

- You are trying to perform a calculation with matrices or vectors whose dimensions do not allow that type of calculation.

**Action:**

- Check the dimensions specified for the matrices or vectors to see if they are compatible with the calculation.
- 

**Variable ERROR (Equation app's Solver feature only)****Cause:**

- An attempt to execute Solver for an expression input without any variable included.

**Action:**

- Input an expression that includes a variable.
- 

**Cannot Solve (Equation app's Solver feature only)****Cause:**

- The calculator could not obtain a solution.

**Action:**

- Check for errors in the equation that you input.
  - Input a value for the solution variable that is close to the expected solution and try again.
- 

**Range ERROR****Cause (Table app):**

- An attempt to generate a number table in the Table app whose conditions cause it to exceed the maximum number of allowable rows.

**Action:**

- Narrow the table calculation range by changing the Start, End, and Step values, and try again.

**Cause (Spreadsheet app):**

- During batch input in the Spreadsheet app, input for Range is outside the allowable range or is a cell name that does not exist.

**Action:**

- For Range, input a cell name within the range of A1 through E45, using the syntax: "A1:A1".

**Cause (Math Box app):**

- The value input as the Attempts (number of trials) for Dice Roll or Coin Toss is outside the allowable range or is a non-integer value.
- The value input on the expression registration screen of Number Line is outside the allowable range, or you entered an inequality with an invalid maximum-minimum relationship (like  $10 < x \leq 5$ ).
- A value input on the View-Window screen of Number Line is outside the allowable range.

**Action:**

- For Attempts, input an integer value that is within the allowable range.
  - On the expression registration screen, input a value that is within the allowable range. In the case of an invalid maximum-minimum relationship for an entered inequality, edit the inequality to correct the maximum-minimum relationship.
  - On the View-Window screen, input values that are within the allowable range.
- 

**Time Out****Cause (differential or integration calculation):**

- The current differential or integration calculation ends without the ending condition being fulfilled.

**Action:**

- Try increasing the *tol* value. Note that this also decreases solution precision.

**Cause (Distribution app):**

- The current distribution calculation ends without the ending condition being fulfilled.

**Action:**

- Change the value of each parameter.
- 

**Circular ERROR****Cause ( $f(x)$  and  $g(x)$  feature):**

- Circular reference is occurring in a registered composite function ("[Registering a Composite Function](#)" (page 72)).

**Action:**

- Do not have  $g(x)$  input into  $f(x)$ , and  $f(x)$  input into  $g(x)$  at the same time.

**Cause (Spreadsheet app):**

- There is a circular reference (such as "=A1" in cell A1) in the spreadsheet.

**Action:**

- Change cell contents to remove the circular references.
- 

**Memory ERROR (Spreadsheet app only)****Cause:**

- You are attempting to input data that exceeds the allowable input capacity (2,380 bytes).

- You are attempting to input data that results in a chain of consecutive cell references (such as cell A2 referenced from cell A1, cell A3 referenced from cell A2..., etc.) This type of input always causes this error to be generated, even if memory capacity (2,380 bytes) is not exceeded.

**Action:**

- Delete unneeded data and input data again.
- Minimize input that results in a chain of consecutive cell references.

## Not Defined

**Cause ( $f(x)$  and  $g(x)$  feature):**

- You attempted to calculate  $f(x)$  or  $g(x)$  with  $f(x)/g(x)$  undefined.

**Action:**

- Define  $f(x)$  or  $g(x)$  before calculating  $f(x)/g(x)$ .

**Cause (Matrix and Vector apps):**

- The matrix or vector you are trying to use in a calculation was input without specifying its dimension.

**Action:**

- Specify the dimension of the matrix or vector and then perform the calculation again.

# Before Assuming Malfunction of the Calculator...

Note that you should make separate copies of important data before performing these steps.

1. Check the calculation expression to make sure that it does not contain any errors.
2. Make sure that you are using the correct calculator app for the type of calculation you are trying to perform.
  - To check which calculator app you are currently using, press  $\odot$ . This highlights the icon of the calculator app currently in use.
3. If the above steps do not correct your problem, press the  $\uparrow$  key.
  - This causes the calculator to perform a routine that checks whether calculation functions are operating correctly. If the calculator discovers any abnormality, it automatically initializes the calculator app and clears memory contents.
4. Return the calculator settings (except for Contrast and Auto Power Off) to their initial default settings by performing the procedure below.
  - (1) Press  $\odot$ , select a calculator app icon, and then press  $\text{OK}$ .
  - (2) Press  $\text{≡}$ , and then select [Reset] > [Settings & Data] > [Yes].

# Replacing the Battery

## Important!

- fx-991CW+ UK sold in EU countries: For safety reasons, please do not replace the battery yourself. Always leave battery replacement up to an authorized CASIO service center.

If the screen shown below appears right after you turn on power, it means that remaining battery power is low.

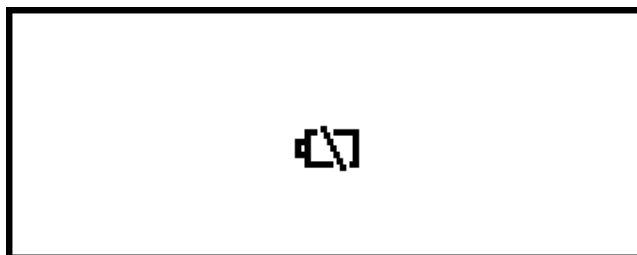

A low battery is also indicated by a dim display, even if contrast is adjusted, or by failure of figures to appear on the display immediately after you turn on the calculator.

If this happens or the above screen appears, contact an authorized CASIO Service Center to have the battery replaced.

## Important!

- Removing the battery causes all of the calculator's memory contents to be cleared.

# Calculation Priority Sequence

The calculator performs calculations according to a calculation priority sequence.

- Basically, calculations are performed from left to right.
- Expressions within parentheses have the highest priority.
- The following shows the priority sequence for each individual command.

1	Parenthetical expressions
2	Functions that have parentheses (sin(, log(, f(, g(, etc., functions that take an argument to the right, functions that require a closing parenthesis after the argument)
3	Functions that come after the input value ( $x^2$ , $x^3$ , $x^{-1}$ , $x!$ , $^{\circ}$ , $^{\circ}$ , $^{\circ}$ , $^{\circ}$ , $^{\circ}$ , $^{\circ}$ , $^{\circ}$ , $^{\circ}$ ), powers ( $x^{\blacksquare}$ ), roots ( $\sqrt{\blacksquare}$ )

4	Fractions
5	Negative sign ((-)), Base Prefix (d, h, b, o)
6	Unit conversion commands (cm ► in, etc.), Statistics app estimated values ( $\hat{x}$ , $\hat{y}$ , $\hat{x}_1$ , $\hat{x}_2$ )
7	Multiplication where the multiplication sign is omitted
8	Permutation ( $nPr$ ), combination ( $nCr$ ), complex number polar coordinate symbol ( $\angle$ )
9	Dot product ( $\bullet$ )
10	Multiplication ( $\times$ ), division ( $\div$ )
11	Addition (+), subtraction (-)
12	and (logical operator)
13	or, xor, xnor (logical operators)

### Precautions when a calculation contains negative values

If a calculation contains a negative value, you may need to enclose the negative value in parentheses. If you want to square the value -2, for example, you need to input:  $(-2)^2$ . This is because  $x^2$  is a function preceded by a value (Priority 3, above), whose priority is greater than the negative sign, which is a prefix symbol (Priority 5).

#### Example:

$$\begin{array}{l} \uparrow \ominus ((-)) 2 \blacksquare^2 \text{EXE} \quad -2^2 = -4 \\ \text{C} \uparrow \ominus ((-)) 2 \text{)} \blacksquare^2 \text{EXE} \quad (-2)^2 = 4 \end{array}$$

### Precautions when using the $\times 10^n$ key in a calculation

The data that is input when you press the  $\times 10^n$  key depends on the current  $\text{☰} - [\text{Calc Settings}] > [\times 10^n \text{ Key}]$  (page 27) setting. Calculation priority depends on the syntax of the formula that is input. Because of this, changing the above setting may affect calculation results even if the formula is input using identical key operations.

To calculate  $100 \div 2 \times 10^2$

### Example 1

When " $\times 10^\square$  (Sci Notat)" is selected for [ $\times 10^\square$  Key] (initial default):  $2 \times 10^2$  calculation priority is higher, so the result is  $100 \div (2 \times 10^2) = \frac{1}{2}$ .

$100 \div 2 \times 10^2 \text{ EXE}$

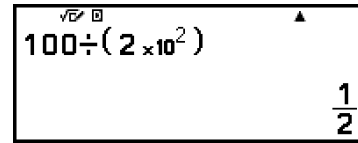

### Example 2

When " $\times 10^\square$  (Power)" is selected for [ $\times 10^\square$  Key]:  $100 \div 2$  calculation priority is higher, so the result is  $(100 \div 2) \times 10^2 = 5000$ .

$100 \div 2 \times 10^2 \text{ EXE}$

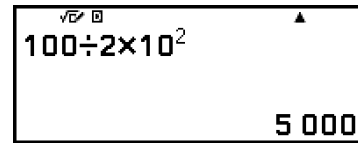

#### Note

- When " $\times 10^\square$  (Sci Notat)" is selected for [ $\times 10^\square$  Key], parentheses will be inserted automatically as shown in the Example 1 above. Note, however, that parentheses will not be inserted automatically if you input the sexagesimal symbol ( $\square$ ) immediately after  $\times 10^\square$ .

$1 \times 10^2 > \uparrow + (0.999) 2 \times 10^2 > \uparrow + (0.999) 3 \times 10^2 > \uparrow + (0.999) \text{ EXE}$

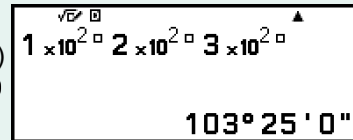

## Calculation Ranges, Number of Digits, and Precision

The calculation range, number of digits used for internal calculation, and calculation precision depend on the type of calculation you are performing.

### Calculation Range and Precision

Calculation Range	$\pm 1 \times 10^{-99}$ to $\pm 9.999999999 \times 10^{99}$ or 0
Number of Digits for Internal Calculation	23 digits

Precision	In general, $\pm 1$ at the 10th digit for a single calculation. Precision for exponential display is $\pm 1$ at the least significant digit. Errors are cumulative in the case of consecutive calculations.
-----------	---

## Function Calculation Input Ranges and Precision

Functions	Input Range	
$\sin x$ $\cos x$	Degree	$0 \leq  x  < 9 \times 10^9$
	Radian	$0 \leq  x  < 157079632.7$
	Gradian	$0 \leq  x  < 1 \times 10^{10}$
$\tan x$	Degree	Same as $\sin x$ , except when $ x  = (2n - 1) \times 90$ .
	Radian	Same as $\sin x$ , except when $ x  = (2n - 1) \times \pi/2$ .
	Gradian	Same as $\sin x$ , except when $ x  = (2n - 1) \times 100$ .
$\sin^{-1}x, \cos^{-1}x$	$0 \leq  x  \leq 1$	
$\tan^{-1}x$	$0 \leq  x  \leq 9.999999999 \times 10^{99}$	
$\sinh x, \cosh x$	$0 \leq  x  \leq 230.2585092$	
$\sinh^{-1}x$	$0 \leq  x  \leq 4.999999999 \times 10^{99}$	
$\cosh^{-1}x$	$1 \leq x \leq 4.999999999 \times 10^{99}$	
$\tanh x$	$0 \leq  x  \leq 9.999999999 \times 10^{99}$	
$\tanh^{-1}x$	$0 \leq  x  \leq 9.999999999 \times 10^{-1}$	
$\log x, \ln x$	$0 < x \leq 9.999999999 \times 10^{99}$	
$10^x$	$-9.999999999 \times 10^{99} \leq x \leq 99.99999999$	
$\sqrt{x}$	$0 \leq x < 1 \times 10^{100}$	

$x^2$	$ x  < 1 \times 10^{50}$
$x^{-1}$	$ x  < 1 \times 10^{100}; x \neq 0$
$x!$	$0 \leq x \leq 69$ ( $x$ is an integer)
$nPr$	$0 \leq n < 1 \times 10^{10}, 0 \leq r \leq n$ ( $n, r$ are integers) $1 \leq \{n!/(n-r)!\} < 1 \times 10^{100}$
$nCr$	$0 \leq n < 1 \times 10^{10}, 0 \leq r \leq n$ ( $n, r$ are integers) $1 \leq n!/r! < 1 \times 10^{100}$ or $1 \leq n!/(n-r)! < 1 \times 10^{100}$
$\text{Pol}(x, y)$	$ x ,  y  \leq 9.999999999 \times 10^{99}$ $\sqrt{x^2 + y^2} \leq 9.999999999 \times 10^{99}$
$\text{Rec}(r, \theta)$	$0 \leq r \leq 9.999999999 \times 10^{99}$ $\theta$ : Same as $\sin x$
$a^\circ b'c''$	$ a , b, c < 1 \times 10^{100}; 0 \leq b, c$ The display seconds value is subject to an error of $\pm 1$ at the second decimal place.
$a^\circ b'c'' = x$	$0^\circ 0' 0'' \leq  x  \leq 99999999^\circ 59' 59''$ A sexagesimal value outside of the above range is automatically treated as a decimal value.
$x^y$	$x > 0: -1 \times 10^{100} < y \log x < 100$ $x = 0: y > 0$ $x < 0: y = n, \frac{m}{2n+1}$ ( $m, n$ are integers) However: $-1 \times 10^{100} < y \log  x  < 100$
$\sqrt[x]{y}$	$y > 0: x \neq 0, -1 \times 10^{100} < 1/x \log y < 100$ $y = 0: x > 0$ $y < 0: x = 2n+1, \frac{2n+1}{m}$ ( $m \neq 0; m, n$ are integers) However: $-1 \times 10^{100} < 1/x \log  y  < 100$
$a^{b/c}$	Total of integer, numerator, and denominator must be 10 digits or less (including separator symbol).
$\text{RanInt}\#(a, b)$	$a < b;  a ,  b  < 1 \times 10^{10}; b - a < 1 \times 10^{10}$
$\text{GCD}(a, b)$	$ a ,  b  < 1 \times 10^{10}$ ( $a, b$ are integers)

LCM( $a, b$ )	$0 \leq a, b < 1 \times 10^{10}$ ( $a, b$ are integers)
---------------	---

- Precision is basically the same as that described under "**Calculation Range and Precision**" (page 161), above.
- $x^y, \sqrt[x]{y}, x!, nPr, nCr$  type functions require consecutive internal calculation, which can cause accumulation of errors that occur with each calculation.
- Error is cumulative and tends to be large in the vicinity of a function's singular point and inflection point.
- The range for calculation results that can be displayed in  $\pi$  form when MathI/MathO is selected for Input/Output on the SETTINGS menu is  $|x| < 10^6$ . Note, however, that internal calculation error can make it impossible to display some calculation results in  $\pi$  form. It also can cause calculation results that should be in decimal form to appear in  $\pi$  form.

## Specifications

---

### Power Requirements:

Built-in solar cell; button battery LR44  $\times$  1

### Approximate Battery Life:

2 years (based on one hour of operation per day)

### Operating Temperature:

0°C to 40°C (32°F to 104°F)

### Dimensions:

10.7 (H)  $\times$  77 (W)  $\times$  162 (D) mm

$7/16$ " (H)  $\times$   $3 1/16$ " (W)  $\times$   $6 3/8$ " (D)

### Approximate Weight:

95 g (3.4 oz) including the battery

# Frequently Asked Questions

---

## Frequently Asked Questions

---

### ■ How can I change a fraction form result produced by a division operation to decimal form?

→ While a fraction calculation result is displayed, press  $\text{FORMAT}$ , or press  $\text{↑} \text{EXE} (\approx)$ . For more information, see ["Toggling Calculation Results between Standard \(Fraction,  \$\pi\$ ,  \$\sqrt{\quad}\$  Form\) and Decimal" \(page 47\)](#). To have calculation results initially appear as decimal values, change the Input/Output setting on the SETTINGS menu to MathI/DecimalO.

### ■ What is the difference between Ans memory and variable memory?

→ Each of these types of memory acts like "containers" for temporary storage of a single value.

**Ans Memory:** Stores the result of the last calculation performed. Use this memory to carry the result of one calculation on to the next.

**Variables:** This memory is helpful when you need to use the same value multiple times in one or more calculations.

### ■ How can I find a function I was using with an older CASIO calculator model on this calculator?

→ This calculator's functions can be accessed from the CATALOG menu that appears when you press  $\text{CATALOG}$  or the CATALOG list that appears when you press  $\text{↑} \text{CATALOG} (: \equiv)$ . For details, see the sections below.

["Using the CATALOG Menu and CATALOG List" \(page 30\)](#)

["Advanced Calculations" \(page 56\)](#)

### ■ With an older CASIO calculator model, I pressed $\text{S+D}$ to change the calculation result display format. What should I do with this calculator?

→ Use  $\text{FORMAT}$  to change the calculation result display format. For details, see ["Changing Calculation Result Format" \(page 47\)](#).

### ■ How can I find out which calculator app I am currently using?

→ Press  $\text{APP}$ . This causes the icon of the calculator app you are currently using to become highlighted.

### ■ How do I calculate $\sin^2 x$

→ For example, to calculate  $\sin^2 30 = \frac{1}{4}$ , enter the calculation below.

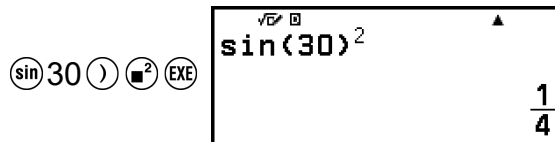

■ **Why can't I input  $i$  or calculate a complex number?**

→ You cannot use the Calculate app to input  $i$  or to perform complex number calculations. Use the Complex app for such calculations.

■ **Why does the battery icon (🔋) appear right after the calculator is turned on?**

→ The battery icon indicates that battery power is low. If you see this icon, replace the battery as soon as possible. For details about battery replacement, see ["Replacing the Battery" \(page 159\)](#).

■ **How can I return the calculator to its initial default settings?**

→ Perform the procedure below to initialize calculator settings (except for Contrast and Auto Power Off).

(1) Press  $\odot$ , select a calculator app icon, and then press  $\text{OK}$ .

(2) Press  $\equiv$ , and then select [Reset] > [Settings & Data] > [Yes].

**CASIO®**

**CASIO COMPUTER CO., LTD.**

6-2, Hon-machi 1-chome  
Shibuya-ku, Tokyo 151-8543, Japan